

Listino n° 3    gennaio 2008  
Price list n° 3    january 2008

## Raccordi per condotte di fluidi in pressione

*Fittings for pressure  
conduits*



# Raccordi con anello di gomma

# Rubber ring fittings

# Raccords à joint caoutchouc

# Accesorios juntas elastica

## CARATTERISTICHE

## TECHNICAL FEATURES

## CARACTERISTIQUES

## CARACTERISTICAS

### Gamma dimensionale

- dal d. 63 mm al d. 315 mm

### Size range

- from d.63 mm up to d.315 mm

### Gamme dimensionnelle

- du d. 63 mm jusqu'au d. 315 mm

### Medidas

- desde d. 63 mm hasta d. 315 mm

### Sistema giunzione

mediante guarnizione elastomerica

### Jointing

by an elastomeric ring

### Système de jonction

avec joint caoutchouc

### Sistema de conexion

con junta elastomerica

### Resistenza a pressioni di esercizio

fino a 10 bar a 20°C  
16 bar su richiesta

### Pressure rating

maximum working pressure:  
10 bar at 20°C  
16 bar upon request

### Pression de service

jusqu'à 10 bar à 20° C  
16 bar sur demande

### Presion de trabajo

hasta 10 bar a 20° C  
16 bar sobre pedido

### Specifiche tecniche

- Raccordi PVC idonei al convogliamento di acqua potabile, bevande e prodotti alimentari in conformità a leggi e normative vigenti
- I raccordi con anello di gomma sono conformi alle norme: DIN 8063, ISO 2045, ISO/DIS 6455, NFT 54.038

### Features

- PVC fittings are suitable for conveying foodstuffs and drinking water and meets the necessary standards and regulations
- Rubber ring fittings are produced conforming to the following standards: DIN 8063, ISO 2045, ISO/DIS 6455, NFT 54.038

### Caractéristiques

- Raccords PVC apte à l'utilisation de l'eau potable et des aliments suivants la réglementation en vigueur
- Gamme complète de raccords avec joint caoutchouc conformes aux normes: DIN 8063, ISO 2045, ISO/DIS 6455, NFT 54.038

### Specificacion es tecnicas

- Accesorios PVC para utilizacion en instalaciones en contacto con agua potable y otros alimentos liquidos segun normas vigentes
- Los accesorios con junta elastica siguen las normas: DIN 8063, ISO 2045, ISO/DIS 6455, NFT 54.038

## Raccordi con anello di gomma

## Rubber ring fittings

## Raccords à joint caoutchouc

## Accesorios juntas elastica

### TETRA

Ti con derivazione  
femmina per incollaggio  
Tee 90° with socket branch  
Te 90° avec derivation femelle à coller  
Te 90° derivacion hembra para colar

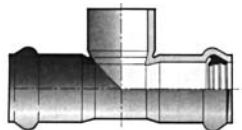

D	€	
	PN 10	PN 16
63	22,06	26,47
75	37,10	44,52
90	41,12	49,34
110	66,19	79,43
125	90,24	108,29
140	212,57	255,08
160	218,59	262,31
200	279,14	334,97

### MARID

Manicotto ridotto F x F  
Reduced socket F x F  
Manchon réduit F x F  
Manguito reducido H x H

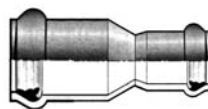

D x d	€	
	PN 10	PN 16
75 x 63	42,17	57,69
90 x 75	49,73	70,85
110 x 90	55,04	87,67
125 x 110	71,69	133,25
140 x 125	93,89	176,33
160 x 140	111,11	204,18
180 x 160	149,75	272,52
200 x 180	182,82	323,52
225 x 200	250,65	369,88
250 x 225	355,73	456,16
280 x 250	416,56	530,66
315 x 280	568,04	709,39
355 x 315	963,12	1.222,27
400 x 355	1.169,29	1.509,01

### AUMENTO

Aumento MxF A. Gomma  
Reduced piece M x F j.c.  
Reduction M x F j.c.  
Reduccion M x H j.e.

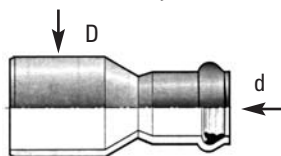

D x d	€	
	PN 10	PN 16
75 x 63	25,10	44,61
90 x 75	46,36	65,13
110 x 75	48,32	71,94
110 x 90	56,04	78,86
125 x 110	79,25	116,55
140 x 110	83,10	126,73
160 x 110	101,25	137,06
160 x 140	110,13	174,72
200 x 160	128,31	178,27
225 x 160	143,00	

### RIDUZIONE

Monogiunto ridotto  
An. gomma / Maschio  
Reducing joint  
Fem. Rubber ring / Spigot end  
Joint réduit  
Fem. caoutchouc / Mâle  
Campana reducida  
Junta elast. Hem. / Macho



D x D1	€	
	PN 10	PN 16
75 x 63	42,51	65,42
90 x 75	49,85	78,02
90 x 63	54,12	79,38
110 x 90	65,61	85,31
110 x 75	71,34	95,08
110 x 63	74,65	101,12
125 x 110	82,63	105,68
125 x 90	90,40	109,99
140 x 125	93,50	116,03
140 x 110	90,40	120,17
160 x 140	96,80	126,05
160 x 110	97,48	128,94
180 x 160	179,46	189,00
200 x 160	223,48	236,25
225 x 160	301,10	309,75
250 x 200	346,79	362,25
280 x 225	363,76	409,50
315 x 250	408,91	441,00

### MONOG

Monogiunto  
Joint M/F  
Joint M/F  
Campana



D	€	
	PN 10	PN 16
63	12,86	16,32
75	17,43	18,91
90	19,79	21,81
110	22,79	26,00
125	28,31	33,86
140	31,17	47,35
160	41,52	67,50
180	48,14	94,57
200	54,98	118,66
225	66,20	135,01
250	84,91	168,76
280	107,45	303,77
315	142,69	337,53

## Raccordi con anello di gomma

## Rubber ring fittings

## Raccords à joint caoutchouc

## Accesorios juntas elastica

### TEE90

Ti a 90°  
Tee 90°  
Te à 90°  
Te 90°



D	€	
	PN 10	PN 16
63	27,68	33,21
75	42,51	51,02
90	57,35	68,82
110	95,66	114,79
125	127,54	153,05
140	180,69	216,83
160	233,84	280,60
200	340,66	408,79
225	627,15	752,58
250	872,31	
280	1.381,93	
315	1.753,81	

### TRFLA

Ti 90° ridotto flangiato  
Flanged reduced Tee 90°  
Te à 90° réduit avec bride  
Te a 90° reducido con brida

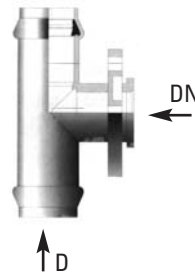

D	€	
	PN 10	PN 16
63 x 63	59,16	103,52
75 x 63	74,64	112,70
75 x 75	74,64	112,70
90 x 63	99,58	160,36
90 x 75	99,58	160,36
90 x 90	99,58	160,36
110 x 63	99,58	208,07
110 x 75	99,58	208,07
110 x 90	156,92	208,07
110 x 110	145,61	208,07
125 x 63	185,15	255,62
125 x 75	185,15	255,62
125 x 90	185,15	255,62
125 x 110	185,15	255,62
125 x 125	185,15	255,62
140 x 63	280,27	287,66
140 x 75	280,27	287,66
140 x 90	280,27	287,66
140 x 110	280,27	287,66
140 x 125	280,27	287,66
140 x 140	280,27	287,66
160 x 63	284,36	349,31
160 x 75	284,36	349,31
160 x 90	284,36	349,31
160 x 110	284,36	349,31
160 x 125	284,36	349,31
160 x 140	284,36	349,31
160 x 160	284,36	349,31
180 x 180	499,00	551,80
200 x 63	502,03	640,76
200 x 75	502,03	640,76
200 x 90	502,03	640,76
200 x 110	502,03	640,76
200 x 125	502,03	640,76
200 x 140	502,03	640,76
200 x 160	502,03	640,76
225 x 160	522,00	740,76
200 x 200	502,03	640,76
225 x 225	591,72	860,06
250 x 250	1.034,09	
280 x 280	1.609,58	
315 x 315	1.706,16	

### TERID

Ti 90° ridotto  
Reduced Tee 90°  
Te à 90° réduit  
Te a 90° reducido



D	€	
	PN 10	PN 16
75 x 63	85,03	102,03
90 x 63	106,29	127,55
90 x 75	106,29	127,55
110 x 63	136,06	163,28
110 x 75	136,06	163,28
110 x 90	136,06	163,28
125 x 63	233,84	280,60
125 x 75	233,84	280,60
125 x 90	233,84	280,60
125 x 110	233,84	280,60
140 x 63	319,54	383,45
140 x 75	319,54	383,45
140 x 90	319,54	383,45
140 x 110	319,54	383,45
140 x 125	319,54	383,45
160 x 63	339,74	407,69
160 x 75	339,74	407,69
160 x 90	339,74	407,69
160 x 110	339,74	407,69
160 x 125	339,74	407,69
160 x 140	339,74	407,69
200 x 63	468,29	561,95
200 x 75	468,29	561,95
200 x 90	468,29	561,95
200 x 110	468,29	561,95
200 x 125	468,29	561,95
200 x 140	468,29	561,95
200 x 160	468,29	561,95
225 x 160	517,14	597,68
250 x 160	922,92	
280 x 200	1.384,39	
315 x 250	1.640,76	

## Raccordi con anello di gomma

## Rubber ring fittings

## Raccords à joint caoutchouc

## Accesorios juntas elastica

### MANIC

Manicotto scorrevole Sleeve socket Manchon coulissant Manguito deslizante	D	€	
		PN 10	PN 16
	50	15,26	16,18
	65	17,81	18,88
	75	18,52	20,74
	90	20,93	25,16
	110	25,44	35,40
	125	32,27	35,99
	140	45,56	51,36
	160	49,20	63,35
	180	64,01	77,61
	200	74,93	92,23
	225	95,73	129,21
	250	126,24	159,88
	280	161,68	195,67
	315	225,51	273,93
	355	438,53	492,58
	400	527,39	



### MARIP

Manicotto scorrevole lungo Sleeve socket (long type) Manchon coulissant longue Manguito deslizante lungo	D	€	
		PN 10	PN 16
	63	21,26	26,26
	75	24,31	29,48
	90	29,88	35,93
	110	36,81	47,53
	125	44,30	53,23
	140	59,69	78,13
	160	72,09	94,11
	180	98,87	123,48
	200	119,81	143,71
	225	166,71	200,57
	250	241,90	294,67
	280	286,35	355,92
	315	360,24	415,21



### TOULIPE RID

Riduzione con flangia Reducing flange adaptor Reduction avec bride Reduccion flangeada	D	€	
		PN 10	PN 16
	75 x 63	64,87	77,65
	90 x 63	80,79	98,16
	90 x 75	80,79	98,16
	110 x 63	109,81	131,84
	110 x 75	109,81	131,84
	110 x 90	109,81	131,84
	125 x 63	149,67	179,46
	125 x 75	149,67	179,46
	125 x 90	149,67	179,46
	125 x 110	149,67	179,46
	140 x 63	173,94	208,76
	140 x 75	173,94	208,76
	140 x 90	173,94	208,76
	140 x 110	173,94	208,76
	140 x 125	173,94	208,76
	160 x 63	192,18	230,73
	160 x 75	192,18	230,73
	160 x 90	192,18	230,73
	160 x 110	192,18	230,73
	160 x 125	192,18	230,73
	160 x 140	192,18	230,73
	200 x 63	380,46	532,66
	200 x 75	380,46	532,66
	200 x 90	380,46	532,66
	200 x 110	380,46	532,66
	200 x 125	380,46	532,66
	200 x 140	380,46	532,66
	200 x 160	380,46	532,66

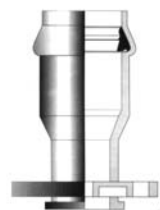

### TOULIPE

Monogiunto flangiato Flanged adaptor Joint d'adaptation à bride Junta con brida	D	€	
		PN 10	PN 16
	63	35,87	46,64
	75	48,66	54,45
	90	54,46	63,09
	110	68,10	91,47
	125	78,95	123,19
	140	91,76	146,82
	160	109,70	175,52
	180	184,59	295,34
	200	203,70	325,93
	225	230,73	369,17
	250	334,00	
	280	418,83	
	315	483,44	

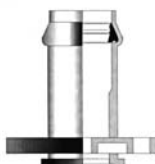

### BOUT

Adattatore maschio flangiato Flanged spigot Joint d'adaptation mâle à bride Junta macho con brida	D	€	
		PN 10	PN 16
	63	26,97	31,01
	75	28,90	41,35
	90	36,74	53,30
	110	45,89	65,86
	125	63,92	89,49
	140	66,38	106,32
	160	88,81	124,34
	180	169,21	215,35
	200	173,39	236,89
	225	186,78	261,49
	250	281,27	
	280	351,59	
	315	395,54	

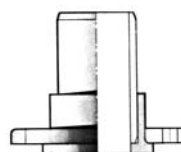

## Raccordi con anello di gomma

## Rubber ring fittings

## Raccords à joint caoutchouc

## Accesorios juntas elastica

### **CUR** Curva - Bicchiere An. gomma / Maschio incollaggio Bend - Rubber ring socket / Spigot end

Curva 11° 15' / 22° 30' / 45° Bend 11° 15' / 22° 30' / 45° Courbe 11° 15' / 22° 30' / 45° Curvas 11° 15' / 22° 30' / 45°	D	€	
		PN 10	PN 16
	63	19,68	23,57
	75	24,04	27,57
	90	33,17	41,45
	110	37,25	51,69
	125	49,74	74,02
	140	61,80	92,94
	160	75,33	110,87
	180	182,66	282,64
	200	200,55	307,81
	225	250,35	357,20
	250	389,78	527,99
	280	487,62	745,37
	315	590,11	869,62
	400	1102,54	

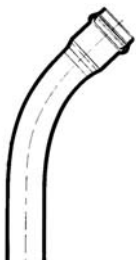

### **CUR90** Courbe - Femelle joint caoutchouc / Mâle à collet Curva - Junta elastica hembra / Macho para colar

Curva 90° Bend 90° Courbe 90° Curvas 90°	D	€	
		PN 10	PN 16
	63	20,34	25,71
	75	24,89	33,17
	90	35,41	48,54
	110	46,64	62,77
	125	60,74	85,61
	140	84,79	121,47
	160	104,68	146,75
	180	217,99	338,64
	200	252,79	366,71
	225	341,64	487,62
	250	395,56	615,32
	280	776,44	1084,09
	315	1010,85	1333,15
	400		

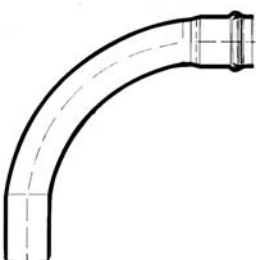

### **CUA** Curva - Doppio Bicchiere An. di Gomma Bend - Double Rubber Ring Socket

Curva 11° 15' / 22° 30' / 45° Bend 11° 15' / 22° 30' / 45° Courbe 11° 15' / 22° 30' / 45° Curvas 11° 15' / 22° 30' / 45°	D	€	
		PN 10	PN 16
	63	22,63	27,11
	75	27,65	31,71
	90	38,15	47,67
	110	42,84	59,44
	125	57,20	85,12
	140	71,07	106,88
	160	86,63	127,50
	180	210,06	325,04
	200	230,63	353,98
	225	287,90	410,78
	250	448,25	607,19
	280	560,76	857,18
	315	678,63	1000,06
	400	1267,92	



### **CUA90** Courbe - Femelle joint caoutchouc Curva - Junta Elastica Hembra

Curva 90° Bend 90° Courbe 90° Curvas 90°	D	€	
		PN 10	PN 16
	63	23,39	29,57
	75	28,62	38,15
	90	40,72	55,82
	110	53,64	72,19
	125	69,85	98,45
	140	97,51	139,69
	160	120,38	168,76
	180	250,69	389,44
	200	290,71	421,72
	225	392,89	560,76
	250	454,89	707,62
	280	892,91	1246,70
	315	1162,48	1533,12
	400		

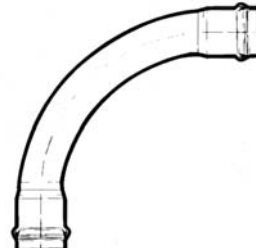

### **CUM**

Curva - Bicchiere Incoll./Maschio Incoll. 11° 15' / 22° 30' / 45°/ 90°  
Bend - Solvent Cement Socket/Spigot End 11° 15' / 22° 30' / 45°/ 90°  
Courbe - Femelle à coller/Mâle à collet 11° 15' / 22° 30' / 45°/ 90°  
Curva - Hembra Para Colar/Macho para colar 11° 15' / 22° 30' / 45°/ 90°

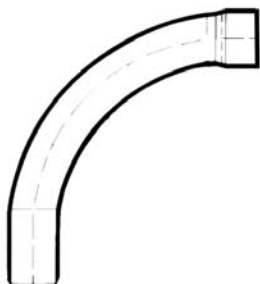

SU RICHIESTA  
UPON REQUEST  
SUR DEMANDE  
SOBRE PEDIDO

### **CUI**

Curva - Doppio Bicchiere Incollaggio 11° 15' / 22° 30' / 45°/ 90°  
Bend - Double Solvent Cement Socket 11° 15' / 22° 30' / 45°/ 90°  
Courbe - Femelles à coller 11° 15' / 22° 30' / 45°/ 90°  
Curva - Hembra Para Colar 11° 15' / 22° 30' / 45°/ 90°

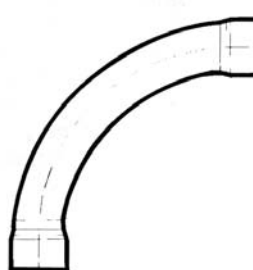

SU RICHIESTA  
UPON REQUEST  
SUR DEMANDE  
SOBRE PEDIDO

## Raccordi in PVC rigido

metrico per incollaggio

filettato cilindrico

di passaggio

### CARATTERISTICHE

#### Materiali

Raccordi: PVC rigido colore grigio non plastificato  
Guarnizioni: EPDM (DUTRAL)

#### Temperatura massima di esercizio

60° C

#### Pressione massima di esercizio

Fino a 16 bar a 20° C (consultare catalogo tecnico)

#### Dimensioni e specifiche tecniche

*Incollaggio per misure metriche* in conformità a ISO 727, DIN 8063, NFT54028, KIWA 54, UNI 7442/75

*Raccordi filettati* in conformità a: BS21

#### Norme sanitarie

Raccordi idonei al convogliamento di acqua potabile, bevande e prodotti alimentari in conformità a leggi e normative dei principali Paesi Europei ed ExtraEuropei

#### Dimensione cartoni

XS = 30x20x20  
S = 40x30x20  
M = 40x30x30  
L = 60x40x30  
L+ = 60x40x50  
XL = 80x120x80

## uPVC pressure fittings

Solvent cement jointing

B. S. P. threaded

Adaptor set

### TECHNICAL FEATURES

#### Materials

Fittings: Grey unplasticized polyvinyl chloride (U-PVC)  
Gaskets: EPDM (DUTRAL)

#### Max working temperature

60° C

#### Max working pressure

Up to 16 bar at 20° C  
(see technical catalogue)

#### Dimensions and specifications

*Solvent welding metric sized ends* according to: ISO 727, DIN 8063, NFT54028, KIWA 54, UNI 7442/75

*Threaded fittings* according to: BS21

#### Sanitary laws

Fittings are suitable to be used in contact with drinking water, wine, beverages and food, according to laws and rules in force in the main European and Extra European Countries

#### Cartons dimension

XS = 30x20x20  
S = 40x30x20  
M = 40x30x30  
L = 60x40x30  
L+ = 60x40x50  
XL = 80x120x80

## Raccords en PVC rigide

Métrique à coller

Avec filetage cylindrique

Série d'adaptation

### CARACTERISTIQUES

#### Matériel

Raccords: PVC gris (chlorure de polyvinyle non plastifié)  
Joints: EPDM (DUTRAL)

#### Max température d'utilisation

60° C

#### Pression nominale

Jusqu'à 16 bar à 20° C  
(voir catalogue technique)

#### Dimensions et caractéristiques

*Raccords à coller série métrique* conformes aux normes: ISO 727, DIN 8063, NFT54028, KIWA 54, UNI 7442/75

*Raccords avec filetage* conformes à: BS21

#### Normes sanitaires

Raccords aptes au transport de l'eau potable, vin, boissons et fluides alimentaires selon les lois en vigueur dans les principaux pays Européens et Extra Communautaires

#### Dimension cartons

XS = 30x20x20  
S = 40x30x20  
M = 40x30x30  
L = 60x40x30  
L+ = 60x40x50  
XL = 80x120x80

## Accesorios de PVC presión

Serie encolar metrica

Serie roscada

Serie mixta

### CARACTERISTICAS

#### Materiales

Accesorios: Cloruro de polivinilo u-PVC gris sin plastificante  
Asiento: EPDM (DUTRAL)

#### Temperatura máxima de trabajo

60° C

#### Presion máxima de trabajo

Asta 16 bar a 20° C  
(consultar catalogo tecnico)

#### Dimensiones y especificaciones tecnicas

*Para union encolada conexion metrica* conforme a: ISO 727, DIN 8063, NFT54028, KIWA 54, UNI 7442/75

*Union roscada* conforme a: BS21

#### Normas sanitarias

Piezas idoneas al transporte de agua potable, vino y fluidos alimenticios segun las leyes y las prescripciones vigentes en Italia y en otros paises Europeos y ExtraEuropeos

#### Dimension cartones

XS = 30x20x20  
S = 40x30x20  
M = 40x30x30  
L = 60x40x30  
L+ = 60x40x50  
XL = 80x120x80

## Raccordi in PVC a pressione

Serie metrica per incollaggio

## UPVC pressure fittings

Metric set for solvent  
cement jointing

## Raccords PVC à pression

Série métrique à coller

## Accesorios PVC a presión

Serie lisa para colar

### G1 SK

	D	€	Pack.
Gomito 90° Elbow 90° Coude 90° Codo 90°	16	0,75	250 XS
	20	0,88	200 XS
	25	1,06	200 S
	32	1,26	120 S
	40	2,23	60 S
	50	3,20	100 L
	63	4,58	60 L
	75	10,04	35 L
	90	13,06	20 L
	110	19,43	10 L
	125	39,86	6 L
	140	48,40	5 L
	160	75,53	4 L
	200	147,77	2 L
	225	185,71	2 L+

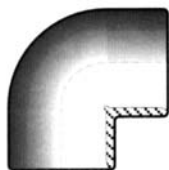

### H1 SK

	D	€	Pack.
Gomito 45° Elbow 45° Coude 45° Codo 45°	16	1,38	600 S
	20	1,47	200 XS
	25	1,69	140 XS
	32	2,26	140 S
	40	2,79	80 S
	50	3,55	40 S
	63	5,58	60 L
	75	9,11	8 S
	90	12,89	6 S
	110	27,52	6 M
	125	36,06	6 L
	140	53,50	6 L
	160	63,18	4 L

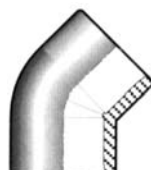

### T1 SK

	D	€	Pack.
Ti a 90° Tee 90° Te à 90° Te a 90°	16	1,09	150 XS
	20	1,09	120 XS
	25	1,26	150 S
	32	1,69	80 S
	40	2,72	40 S
	50	3,90	80 L
	63	5,87	40 L
	75	10,96	25 L
	90	15,66	12 L
	110	25,57	8 L
	125	52,88	6 L
	140	72,16	6 L+
	160	87,30	5 L+
	200	177,62	2 L+
	225	223,88	1 L

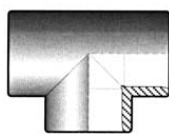

### M1 SK

	D	€	Pack.
Manicotto Double socket Manchon Manguito	16	0,70	300 XS
	20	0,70	250 XS
	25	0,75	380 S
	32	0,81	200 S
	40	1,29	100 S
	50	1,69	200 L
	63	2,36	100 L
	75	5,68	24 S
	90	9,47	30 L
	110	13,13	24 L
	125	21,95	14 L
	140	28,51	8 L
	160	33,96	6 L
	200	81,41	6 L+
	225	93,17	2 L

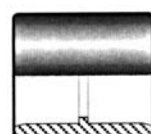

### C1 SK

	D	€	Pack.
Calotta Cap Bouchon femelle Tapon hembra	16	0,85	500 XS
	20	0,85	300 XS
	25	0,85	200 XS
	32	1,03	120 XS
	40	1,38	70 XS
	50	1,98	80 S
	63	2,68	60 M
	75	6,52	14 XS
	90	8,78	15 S
	110	12,54	10 S
	125	21,10	3 XS
	140	22,63	4 S
	160	31,87	4 M
	200	69,68	7 L
	225	77,28	6 L
	250	137,80	6 L



### QR1 SK

	D	€	Pack.
Collare rigato Stub serrated Collet strié pour bride Manguito portabridas	20	0,75	1400 M
	25	0,84	750 M
	32	0,98	400 M
	40	1,60	250 M
	50	2,30	120 M
	63	4,25	80 M
	75	6,52	50 M
	90	7,84	60 L
	110	10,38	40 L
	125	22,21	25 L
	140	24,31	20 L
	160	27,41	10 L
	200	52,88	7 L
	225	56,22	6 L
	250	81,66	4 L



**ODSK**

	<b>D</b>	<b>€</b>	<b>Pack.</b>
Flangia libera			
Loose flange	20	2,82	250 M
Bride libre	25	3,10	200 M
Brida loca	32	3,55	150 M
	40	5,09	100 M
	50	5,50	80 M
	63	6,42	14 XS
	75	8,82	14 XS
	90	10,15	24 M
	110	11,80	20 M
	125	15,50	30 L
	FAI 125	17,67	25 L
	140	17,67	25 L
	160	22,21	20 L
	200	44,03	10 L
	225	46,98	10 L
	250	76,78	6 L

**TR1 SK**

	<b>D</b>	<b>€</b>	<b>Pack.</b>
Tee ridotto 90°			
Reduced Tee 90°	20 x 16	1,56	400 M
Te à 90° réduit	25 x 16	1,56	250 M
Te a 90° reducida	25 x 20	1,56	250 M
	32 x 16	1,72	150 M
	32 x 20	1,72	150 M
	32 x 25	1,72	150 M
	40 x 16	2,85	70 M
	40 x 20	2,85	70 M
	40 x 25	2,85	70 M
	40 x 32	2,85	70 M
	50 x 20	3,90	90 L
	50 x 25	3,90	90 L
	50 x 32	3,90	90 L
	50 x 40	3,90	90 L
	63 x 20	6,18	60 L
	63 x 25	6,18	60 L
	63 x 32	6,18	50 L
	63 x 40	6,18	50 L
	63 x 50	6,18	50 L
	75 x 32	11,58	35 L
	75 x 40	11,58	30 L
	75 x 50	11,58	30 L
	75 x 63	11,58	30 L
	90 x 40	16,92	20 L
	90 x 50	16,92	20 L
	90 x 63	16,92	20 L
	90 x 75	16,92	20 L
	110 x 50	25,99	12 L
	110 x 63	25,99	12 L
	110 x 75	25,99	10 L
	110 x 90	25,99	10 L
	125 x 63	66,21	6 L
	125 x 75	66,21	6 L
	125 x 90	66,21	6 L
	125 x 110	66,21	6 L
	140 x 75	92,95	4 L
	140 x 90	92,95	4 L
	140 x 110	92,95	4 L
	140 x 125	92,95	4 L
	160 x 90	98,04	3 L
	160 x 110	98,04	3 L
	160 x 125	98,04	3 L
	160 x 140	98,04	3 L

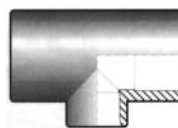
**FDSK**

	<b>D</b>	<b>€</b>	<b>Pack.</b>
Flangia fissa			
Fixed flange	20	3,24	150 M
Bride fixe	25	4,25	120 M
Brida fija	32	5,09	80 M
	40	6,59	60 M
	50	7,77	40 M
	63	9,95	25 M
	75	12,39	15 M
	90	15,25	10 L
	110	20,12	20 L

**FCSK**

	<b>D</b>	<b>€</b>	<b>Pack.</b>
Flangia cieca			
Blank flange	20	4,59	250 M
Bride d'opturation	25	5,24	150 M
Brida ciega	32	7,02	150 M
	40	8,94	90 M
	50	11,03	70 M
	63	13,61	40 M
	75	17,96	35 M
	90	20,94	30 M
	110	27,21	20 M
	125	31,40	20 M
	140	37,05	16 M
	160	55,13	12 M
	200	81,97	8 L
	225	81,97	8 L
	250	278,72	6 L
	280	284,62	4 L

**A1 SK**

	<b>D</b>	<b>€</b>	<b>Pack.</b>
Portagomma			
Hose nozzle	16 x 18 x 16	1,45	500 XS
Douille	20 x 22 x 20	1,63	300 XS
Espiga	25x27x25	2,01	250 XS
	32x32x30	2,22	100 XS
	40x42x40	3,25	100 S
	50x52x50	4,04	50 S
	63x64x60	5,08	40 S



**D4SK**

Bussola di riduzione  
Reducing bush  
Reduction M/F simple  
Casquillo M/H



	<b>D</b>	€	<b>Pack.</b>
	20 x 16	0,70	4000 M
	25 x 16	0,70	2200 M
	25 x 20	0,70	2200 M
	32 x 16	0,88	1100 M
	32 x 20	0,88	1100 M
	32 x 25	0,88	1100 M
	40 x 20	1,03	600 M
	40 x 25	1,03	600 M
	40 x 32	1,03	600 M
	50 x 20	1,24	300 M
	50 x 25	1,24	300 M
	50 x 32	1,24	300 M
	50 x 40	1,24	100 XS
	63 x 32	1,84	150 M
	63 x 40	1,84	150 M
	63 x 50	1,84	100 S
	75 x 40	3,16	100 M
	75 x 50	3,16	100 M
	75 x 63	3,16	30 XS
	90 x 50	6,30	36 S
	90 x 63	6,30	36 S
	90 x 75	6,30	20 XS
	110 x 63	9,28	55 L
	110 x 75	9,28	18 S
	110 x 90	9,28	18 S
	125 x 75	13,83	12 S
	125 x 90	13,83	12 S
	125 x 110	13,83	12 S
	140 x 90	19,55	30 L
	140 x 110	19,55	30 L
	140 x 125	19,55	30 L
	160 x 90	21,80	20 L
	160 x 110	21,80	20 L
	160 x 125	21,80	20 L
	160 x 140	21,80	20 L
	180 x 125	37,27	18 L
	180 x 140	37,27	18 L
	180 x 160	37,27	18 L
	200 x 160	41,73	10 L
	200 x 180	41,73	10 L
	225 x 160	46,88	7 L
	225 x 200	46,88	7 L

**R4SK**

Riduzione M/F  
Reduced piece M/F  
Reduction M/F  
Reduccion M/H

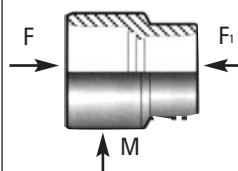

	<b>D</b>	€	<b>Pack.</b>
	F - M - F <sub>1</sub>		300 XS
	20 x 16	0,91	600 S
	20 x 25 x 16	1,06	600 S
	20 x 25 x 20	1,06	300 S
	25 x 32 x 16	1,21	300 S
	25 x 32 x 20	1,21	280 S
	25 x 32 x 25	1,21	200 S
	32 x 40 x 20	1,53	170 S
	32 x 40 x 25	1,53	350 M
	32 x 40 x 32	1,53	240 M
	40 x 50 x 20	1,93	230 M
	40 x 50 x 25	1,93	200 M
	40 x 50 x 32	1,93	190 M
	40 x 50 x 40	1,93	130 M
	50 x 63 x 25	2,91	125 M
	50 x 63 x 32	2,91	120 M
	50 x 63 x 40	2,91	100 M
	50 x 63 x 50	2,91	80 M
	63 x 75 x 40	7,24	80 M
	63 x 75 x 50	7,24	60 M
	63 x 75 x 63	7,24	45 M
	75 x 90 x 40	9,98	45 M
	75 x 90 x 50	9,98	36 M
	75 x 90 x 63	9,98	80 M
	75 x 90 x 75	9,98	45 M
	90 x 110 x 40	12,89	45 M
	90 x 110 x 50	12,89	45 M
	90 x 110 x 63	12,89	45 L
	90 x 110 x 75	12,89	45 L
	90 x 110 x 90	12,89	42 L
	110 x 125 x 50	18,43	42 L
	110 x 125 x 63	18,43	42 L
	110 x 125 x 75	18,43	42 L
	110 x 125 x 90	18,43	27 L
	110 x 125 x 110	18,43	30 L
	140 x 90	29,23	20 L
	140 x 110	29,23	20 L
	140 x 125	29,23	16 L
	160 x 90	37,05	16 L
	160 x 110	37,05	12 L
	160 x 125	45,50	12 L
	160 x 140	83,73	8 L

**Y1SK**

Tee a 45°  
45° Tee  
Te à 45°  
Tes 45°

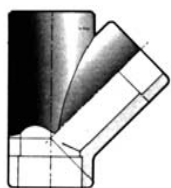

D	€
20	3,51
25	4,04
32	4,41
40	6,16
50	8,03
63	11,16
75	35,88
90	85,83
110	123,02
160	133,75

**X1SK**

Croce  
Cross  
Croix  
Cruz



D	€	Pack.
25	4,57	40 S
32	7,80	50 S
40	8,55	40 M
50	9,74	20 M
63	14,45	12 M
75	32,53	9 M
90	55,04	17 L
110	84,39	8 L

**UE1SK**

Pezzo folle per UN80  
Union end for UN80  
Embout pour UN80  
Mnguito para UN80



D	€	Pack.
16	0,91	1000 S
20	1,05	800 S
25	1,05	400 M
32	1,53	570 M
40	1,86	320 M
50	2,49	140 M
63	3,47	100 L
75	9,34	130 L
90	11,27	80 L
110	13,52	40 L

**UB1SK**

Pezzo fisso per UN80  
Union bush for UN80  
Mamelon pour UN80  
Pieza fixapara UN80



D	€	Pack.
16	1,22	600 S
20	1,45	500 S
25	1,61	280 S
32	2,26	450 M
40	2,74	200 M
50	3,70	120 M
63	4,91	70 L
75	13,61	100 L
90	14,57	64 L
110	17,55	30 L

**B1SK**

Bocchettone O-ring  
Union with O-ring  
Union 3 pièces  
Enlace 3 piezas

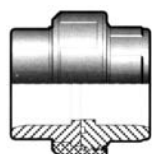

D	€	Pack.
16	3,41	150 S+
20	3,41	180 S+
25	3,55	100 S+
32	4,84	70 S+
40	6,08	40 S+
50	7,94	90 L
63	11,09	45 L
75	34,40	28 L
90	39,86	22 L
110	45,89	15 L

**E2SK**

Ghiera  
Nut for union  
Ecrou  
Tuerca



D	R	€	Pack.
16	3/4"	1,53	350 S
20	1"	2,09	600 M
25	1 1/4"	3,47	450 M
32	1 1/2"	4,91	300 M
40	2"	8,86	180 M
50	2 1/4"	8,86	280 L
63	2 3/4"	13,69	160 L
75	3 1/2"	27,53	90 L
90	4"	29,07	64 L
110	5"	42,84	30 L

**Serie metrica per incollaggio**

**Metric set for solvent**

**Série métrique à coller**

**Serie lisa para colar**

**cement jointing**

**S1 SK**

	<b>D</b>	<b>€</b>	<b>Pack.</b>
Curva 90° Bend 90° Courbe à 90° Curva a 90°	20	3,90	300 M
	25	4,49	150 M
	32	5,68	90 M
	40	8,01	100 L
	50	10,70	50 L
	63	14,61	25 L
	75	30,13	15 L
	90	40,85	10 L
	110	66,11	5 L
	125	109,21	6 L
	140	110,43	4 L+
	160	111,64	4 L+



**MR1 SK**

	<b>D</b>	<b>€</b>	<b>Pack.</b>
Manicotto ridotto Reducing socket Manchon réduit Manguito reducido	20 x 16	0,88	1000 M
	25 x 20	0,88	500 M
	32 x 25	1,17	300 M
	40 x 32	1,47	150 M
	50 x 40	2,07	100 M
	63 x 50	2,89	90 M
	75 x 63	5,93	50 M
	90 x 75	9,36	50 L
	110 x 90	14,24	35 L
	125 x 110	22,63	16 L
	140 x 110	28,51	15 L
	140 x 125	30,56	10 L
	160 x 110	39,29	8 L
	160 x 140	39,29	8 L
	200 x 160	61,35	4 L
	225 x 200	153,37	2 L

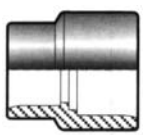

**G/ST**

	<b>D</b>	<b>€</b>
Guarniz. piana per ST20 Flat gasket for ST20 Joint plat pour ST20 Guarnicion para ST20	20	0,52
	25	0,56
	32	0,60
	40	1,12
	50	1,47
	63	1,61
	75	2,09
	90	2,17
	110	4,35
	125	5,15
	140	6,05
	160	8,05
	200	11,92
	225	13,77
	250	21,25
	300	36,63



**G/UN**

	<b>D</b>	<b>€</b>
O-ring per UN80 O-ring gasket for UN80 Joint O-ring pour UN80 O-ring para UN80	16	0,84
	20	0,84
	25	1,21
	32	1,24
	40	2,06
	50	2,33
	63	2,49
	75	3,79
	90	5,56
	110	7,08



## Raccordi in PVC a pressione

Serie filettata cilindrica

## UPVC pressure fittings

Threaded serie

## Raccords PVC à pression

Série fileté/taraudée

## Accesorios PVC a presión

Serie roscada metrica

### G2SK

	D	€	Pack.
Gomito 90° 90° elbow Coude 90° Codo a 90°	3/8"	1,43	1100 M
	1/2"	1,43	130 XS
	3/4"	1,60	150 S
	1"	1,90	120 M
	1 1/4"	3,10	100 M
	1 1/2"	4,70	60 M
	2"	6,68	50 L
	2 1/2"	16,42	40 L
	3"	23,21	25 L
	4"	38,18	14 L



### H2SK

	D	€	Pack.
Gomito 45° 45° elbow Coude 45° Codo a 45°	3/8"	2,12	600 S
	1/2"	2,79	800 M
	3/4"	3,02	500 M
	1"	3,74	250 M
	1 1/4"	5,09	150 M
	1 1/2"	6,75	170 M
	2"	9,87	90 L
	2 1/2"	24,96	50 L
	3"	31,28	30 L
	4"	47,83	16 L

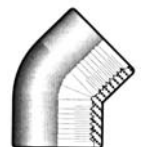

### T2SK

	D	€	Pack.
Ti a 90° 90° Tee Té 90° Te a 90°	3/8"	2,05	700 M
	1/2"	2,05	500 M
	3/4"	2,08	280 M
	1"	2,62	150 M
	1 1/4"	3,55	70 M
	1 1/2"	5,54	90 L
	2"	8,10	45 L
	2 1/2"	20,28	30 L
	3"	26,16	18 L
	4"	46,98	10 L

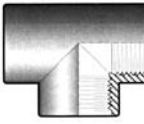

### M2SK

	D	€	Pack.
Maniccotto Double socket Manchon Manguito	3/8"	1,40	1300 M
	1/2"	1,40	400 S
	3/4"	1,49	550 M
	1"	1,90	300 M
	1 1/4"	2,53	150 M
	1 1/2"	3,55	120 M
	2"	4,84	85 M
	2 1/2"	14,08	80 L
	3"	16,99	60 L
	4"	24,31	35 L

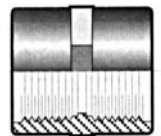

### N2SK

	D	€	Pack.
Nipplo Nipple Mamelon Niple	3/8"	1,03	2400 M
	1/2"	1,09	1000 M
	3/4"	1,35	600 M
	1"	1,69	400 M
	1 1/4"	2,10	200 M
	1 1/2"	2,43	150 M
	2"	3,49	80 M
	2 1/2"	9,19	100 L
	3"	12,54	70 L
	4"	19,61	35 L

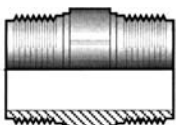

### C2SK

	D	€	Pack.
Calotta Cap Bouchon femelle Tapon hembra	3/8"	1,43	500 XS
	1/2"	1,43	250 XS
	3/4"	1,43	200 XS
	1"	1,56	100 XS
	1 1/4"	2,30	70 S
	1 1/2"	2,65	90 S
	2"	3,74	50 S
	2 1/2"	12,73	70 M
	3"	16,99	40 M
	4"	21,38	60 L



**NR2SK**

	<b>D</b>	€	<b>Pack.</b>
Nipplo ridotto	1/2" x 3/8"	1,52	600 S
Reduced nipple	3/4" x 1/2"	1,76	350 S
Mamelon réduit	1" x 3/4"	2,23	500 M
Niple reducido	1 1/4" x 1"	2,82	270 M
	1 1/2" x 1 1/4"	3,49	180 M
	2" x 1 1/2"	5,09	110 M
	2 1/2" x 2"	9,87	80 M
	3" x 2 1/2"	12,05	35 M
	4" x 3"	18,44	24 M

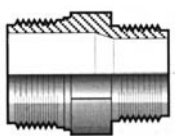
**R2SK**

	<b>D</b>	€	<b>Pack.</b>
Riduzione M/F	M x F		
Reducer M/F	1/2" x 3/8"	1,24	650 S
Reduction M/F	3/4" x 3/8"	1,24	400 S
Reduccion M/F	3/4" x 1/2"	1,24	350 S
	1" x 3/8"	1,56	250 S
	1" x 1/2"	1,56	250 S
	1" x 3/4"	1,56	500 M
	1 1/4" x 1/2"	2,19	300 M
	1 1/4" x 3/4"	2,19	280 M
	1 1/4" x 1"	2,19	260 M
	1 1/2" x 3/4"	2,82	220 M
	1 1/2" x 1"	2,82	200 M
	1 1/2" x 1 1/4"	2,82	180 M
	2" x 1"	3,90	120 M
	2" x 1 1/4"	3,90	110 M
	2" x 1 1/2"	3,90	110 M
	2 1/2" x 1 1/4"	7,84	85 M
	2 1/2" x 1 1/2"	7,84	85 M
	2 1/2" x 2"	7,84	60 M
	3" x 1 1/2"	12,14	60 M
	3" x 2"	12,14	60 M
	3" x 2 1/2"	12,14	45 M
	4" x 2"	19,68	30 M
	4" x 2 1/2"	19,68	30 M
	4" x 3"	19,68	45 L

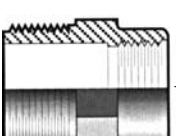
**D2SK**

	<b>D</b>	€	<b>Pack.</b>
Bussola M/F	M x F		
Reducing bush M/F	3/4" x 1/2"	1,53	500 S
Reduction M/F	1" x 3/4"	1,93	320 S
Casquillo M/F	1 1/4" x 1"	2,74	380 M
	1 1/2" x 1 1/4"	3,47	300 M
	2" x 1 1/2"	4,67	160 M
	2 1/2" x 2"	19,32	90 M
	3" x 2 1/2"	20,13	60 M
	4" x 3"	24,80	30 M

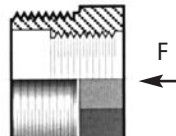
**IF2SK**

	<b>D</b>	€	<b>Pack.</b>
Maggiore M/F	M x F		
Threaded riser M/F	3/8" x 1/2"	2,15	500 S
Adaptation fileté M/F	1/2" x 3/4"	2,26	300 S
Aumento M/H	3/4" x 1"	2,40	150 S
	1" x 1 1/4"	2,58	220 M
	1 1/4" x 1 1/2"	2,98	150 M
	1 1/2" x 2"	4,00	140 M
	2" x 2 1/2"	8,78	72 M
	2" x 3"	10,88	45 M
	3" x 4"	18,44	24 M

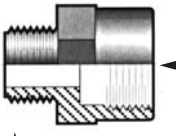
**UE2SK**

	<b>D</b>	€	<b>Pack.</b>
Pezzo folle per UN81	3/8"	1,64	1000 S
Union end for UN81	1/2"	1,64	800 S
Embout pour UN81	3/4"	1,64	400 S
Manguito enlace	1"	2,23	570 M
	1 1/4"	2,65	320 M
	1 1/2"	3,65	140 M
	2"	4,98	100 M
	2 1/2"	12,54	130 L
	3"	13,57	80 L
	4"	15,90	40 L

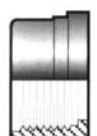
**MR2SK**

	<b>D</b>	€	<b>Pack.</b>
Manicotto ridotto	1/2" x 3/8"	2,40	450 S
Reducing socket	3/4" x 1/2"	2,40	600 M
Manchon réduit	1" x 3/4"	2,58	350 M
Manguito reducido	1 1/4" x 1"	3,24	200 M
	1 1/2" x 1 1/4"	4,73	160 M
	2" x 1 1/2"	6,68	100 M
	2 1/2" x 2"	14,41	60 M
	3" x 2 1/2"	17,16	35 M
	4" x 3"	24,73	24 M

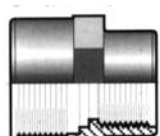

Serie filettata cilindrica

Threaded serie

Série filetée taraudée

Serie roscada metrica

**A2SK**

	D	€	Pack.
Portagomma	1/4"	1,15	1000 S
Hose nozzle	3/8"	1,25	300 XS
Douille filetée	1/2"	1,75	250 XS
Espiga	3/4"	1,92	100 XS
	1"	2,17	100 S
	1 1/4"	3,27	50 S
	1 1/2"	3,88	40 S
	2"	6,19	40 M

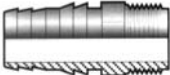

**P2SK**

	D	€	Pack.
Tappo	3/8"	1,09	1750 S
Plug	1/2"	1,09	800 S
Bouchon male	3/4"	1,09	500 S
Tapon macho	1"	1,35	300 S
	1 1/4"	1,98	350 M
	1 1/2"	2,30	280 M
	2"	3,06	160 M
	2 1/2"	10,88	80 M
	3"	12,73	60 M
	4"	21,80	30 M



**B2SK**

	D	€	Pack.
Bocchettone	3/8"	4,49	200 S
Union with O-ring	1/2"	4,49	180 S
Union taraudée 3 pièces	3/4"	5,09	220 M
Enlace 3 piezas	1"	6,59	150 M
	1 1/4"	8,10	80 M
	1 1/2"	11,21	60 M
	2"	15,08	30 M
	2 1/2"	42,35	35 L
	3"	48,65	24 L
	4"	56,22	12 L



**UB2SK**

	D	€	Pack.
Pezzo fisso per UN81	3/8"	1,77	600 S
Union bush for UN81	1/2"	1,93	500 S
Mamelon pour UN81	3/4"	2,26	280 S
Pieza Fija para UN81	1"	2,91	450 M
	1 1/4"	3,47	200 M
	1 1/2"	4,84	120 M
	2"	6,68	70 M
	2 1/2"	19,32	100 L
	3"	22,39	64 L
	4"	24,80	30 L



**J2SK**

	D	€	Pack.
Ghiera	1/2"	3,18	800 S
Backnut	3/4"	3,84	1250 M
Ecrou	1"	4,29	600 M
Tuerca fina	1 1/4"	5,01	450 M
	1 1/2"	6,22	300 M
	2"	9,16	150 M



**TA9SK**

	D	€	Pack.
Attacco a serbatoio	1 1/2"	12,24	50M
Tank adaptor			
Raccord de reservoir			
Adaptator roscado para tanque			

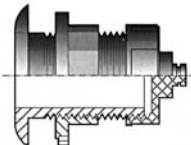

**BNSK**

	D	L	€	Pack.
Barra filettata	1/2"	60	4,10	320 S
Barrel nipple long	3/4"	60	4,42	240 M
Manchon double long	1"	80	4,67	260 M
Manguito roscado	1 1/4"	80	6,19	160 M
	1 1/2"	80	6,77	100 M
	2"	100	7,17	60 M
	2 1/2"	120	11,52	50 M
	3"	130	12,40	60 L
	4"	130	15,38	30 L

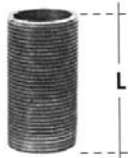

**TA2SK\***

	D	€
Attacco a serbatoio PVC	1/2"	10,22
Tank adaptor PVC	3/4"	11,27
Raccord de reservoir PVC	1"	13,85
Adaptator roscado para tanque PVC	1 1/4"	19,73
	1 1/2"	23,43
	2"	29,88
	2 1/2"	37,44
	3"	42,12
	4"	53,87



\* ( n° 1 BNSK + n° 2 J2SK + n° 2 G/ST - Singolo set impacchettato)

\* ( n° 1 BNSK + n° 2 J2SK + n° 2 G/ST - Each set in a bag)

\* ( n° 1 BNSK + n° 2 J2SK + n° 2 G/ST - Conditione sur sache)

\* ( n° 1 BNSK + n° 2 J2SK + n° 2 G/ST - Embalado en bolsa de plastico)

## Raccordi in PVC a pressione

Serie di passaggio

## UPVC pressure fittings

Adaptor serie

## Raccords PVC à pression

Série d'adaptation

## Accesorios PVC a presión

Serie mixta

### G3SK

	D	€	Pack.
Gomito 90° 90° elbow Coude 90° Codo a 90°	16 x 3/8"	1,52	1100 M
	20 x 1/2"	1,52	130 XS
	25 x 3/4"	1,84	150 S
	32 x 1"	2,30	120 M
	40 x 1 1/4"	4,14	100 M
	50 x 1 1/2"	5,71	60 M
	63 x 2"	7,84	50 L
	75 x 2 1/2"	17,10	40 L
	90 x 3"	24,73	25 L
	110 x 4"	38,24	14 L

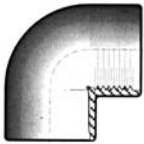

### T3SK

	D	€	Pack.
Ti a 90° 90° Tee Té 90° Te a 90°	16 x 3/8"	1,76	700 M
	20 x 1/2"	1,76	220 S
	25 x 3/4"	2,19	280 M
	32 x 1"	2,82	150 M
	40 x 1 1/4"	3,90	70 M
	50 x 1 1/2"	5,76	90 L
	63 x 2"	9,60	45 L
	75 x 2 1/2"	18,35	30 L
	90 x 3"	26,62	18 L
	110 x 4"	43,62	10 L

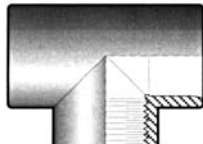

### H3SK

	D	€	Pack.
Gomito 45° 45° elbow Coude 45° Codo a 45°	16 x 3/8"	2,65	600 S
	20 x 1/2"	2,76	800 M
	25 x 3/4"	2,96	500 M
	32 x 1"	3,70	250 M
	40 x 1 1/4"	5,07	150 M
	50 x 1 1/2"	6,44	170 L
	63 x 2"	9,66	90 L
	75 x 2 1/2"	20,29	50 L
	90 x 3"	26,25	30 L
	110 x 4"	46,62	16 L

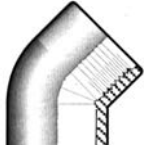

### M3SK

	D	€	Pack.
Manicotto Double socket Manchon Manguito	16 x 3/8"	1,43	800 S
	20 x 1/2"	1,43	400 S
	25 x 3/4"	1,52	270 S
	32 x 1"	1,72	340 M
	40 x 1 1/4"	2,47	180 M
	50 x 1 1/2"	3,83	120 M
	63 x 2"	5,09	75 M
	75 x 2 1/2"	15,08	45 M
	90 x 3"	16,99	54 L
	110 x 4"	24,73	30 L

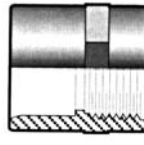

### RB3SK

	D	€	Pack.
Bussola di riduzione Reducing bush Douille de reduction Casquillo	M x F		
	25 x 1/2"	1,13	1000 S
	32 x 3/4"	1,33	550 S
	40 x 1"	2,09	300 S
	50 x 1 1/4"	2,66	350 M
	63 x 1 1/2"	3,49	180 M
	75 x 2"	7,98	110 M
	90 x 2 1/2"	11,09	65 M
	110 x 3"	20,54	40 M



### AD2SK

	D	€	Pack.
Adattatore maschio Adaptor male threaded Embout male Adaptator macho	F x M		
	90 x 3"	12,89	68 L
	110 x 4"	18,27	30 L
	160 x 6"	43,47	8 L

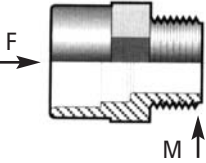

**D3SK**

Adattatore femmina Adaptor fem. threaded Embout femelle Adaptator hembra	<b>MxFxR</b>	€	<b>Pack.</b>
	M x F x R		
	16 x 3/8"	1,29	700 S
	16 x 1/2"	1,29	450 S
	20 x 16 x 1/2"	1,29	400 S
	20 x 3/4"	1,39	300 S
	25 x 20 x 1/2"	1,39	600 M
	25 x 20 x 3/4"	1,67	550 M
	25 x 1"	1,67	350 M
	32 x 25 x 3/4"	2,26	450 M
	32 x 25 x 1"	2,26	300 M
	40 x 32 x 1"	2,26	250 M
	40 x 32 x 11/4"	2,26	180 M
	50 x 40 x 11/4"	2,98	140 M
	50 x 40 x 11/2"	2,98	130 M
	50 x 2"	4,14	100 M
	63 x 50 x 11/2"	5,43	90 M
	63 x 50 x 2"	5,43	70 M
	75 x 63 x 2"	7,84	55 M
	75 x 63 x 21/2"	8,62	80 M
	75 x 3"	10,04	35 L
	90 x 75 x 21/2"	10,96	60 L
	90 x 75 x 3"	10,96	55 L
	90 x 4"	16,59	35 L
	110 x 90 x 3"	16,59	35 L
	110 x 90 x 4"	20,12	35 L
	125 x 110 x 4"	21,37	30 L

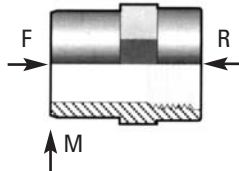
**K3SK**

Adattatore Adaptor male threaded Embout male Adaptator macho	<b>D</b>	€	<b>Pack.</b>
	F x M x R		
	12 x 16 x 3/8"	1,10	1200 S
	16 x 20 x 3/8"	1,03	600 S
	16 x 20 x 1/2"	1,03	500 S
	20 x 25 x 3/8"	1,13	500 S
	20 x 25 x 1/2"	1,13	400 S
	20 x 25 x 3/4"	1,13	350 S
	25 x 32 x 1/2"	1,26	500 M
	25 x 32 x 3/4"	1,26	500 M
	25 x 32 x 1"	1,26	400 M
	32 x 40 x 3/4"	1,52	330 M
	32 x 40 x 1"	1,52	300 M
	32 x 40 x 11/4"	1,52	240 M
	40 x 50 x 1"	2,19	160 M
	40 x 50 x 11/4"	2,19	150 M
	40 x 50 x 11/2"	2,19	140 M
	50 x 63 x 11/4"	3,28	120 M
	50 x 63 x 11/2"	3,28	120 M
	50 x 63 x 2"	3,28	170 L
	63 x 75 x 11/2"	3,94	90 M
	63 x 75 x 2"	3,94	90 M
	63 x 75 x 21/2"	3,94	90 L
	75 x 90 x 2"	11,80	45 M
	75 x 90 x 21/2"	11,80	45 M
	75 x 90 x 3"	11,80	60 L
	90 x 110 x 21/2"	14,24	45 L
	90 x 110 x 3"	14,24	45 L
	90 x 110 x 4"	21,38	35 L
	110 x 125 x 3"	21,38	36 L
	110 x 125 x 4"	21,38	30 L

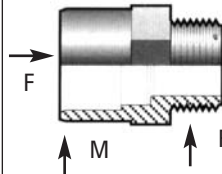
**BM3SK**

Bocchettone maschio Union male Union mâle Enlace rosca macho	<b>D</b>	€	<b>Pack.</b>
	50 x 11/2"	11,99	50 M
	50 x 2"	12,31	50 M
	63 x 2"	15,73	30 M

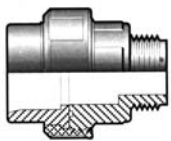
**B3SK**

Bocchettone Union with O-ring Union 3 pièces Enlace tres piezas	<b>D</b>	€	<b>Pack.</b>
	16 x 3/8"	4,73	200 S
	20 x 1/2"	4,73	180 S
	25 x 3/4"	5,37	220 M
	32 x 1"	7,18	150 M
	40 x 11/4"	8,44	80 M
	50 x 11/2"	11,88	60 M
	63 x 2"	15,58	50 M
	75 x 21/2"	37,66	35 L
	90 x 3"	43,20	24 L
	110 x 4"	50,69	12 L

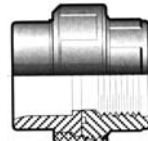
**A3SK**

Portagomma ghiera Hose nozzle with nut Douille avec ecrou Espiga	<b>D</b>	€	<b>Pack.</b>
	3/4" x 18 x 16	3,29	150 S
	1" x 22 x 20	3,67	120 S
	11/4" x 27 x 25	4,59	160 M
	11/2" x 32 x 30	6,12	120 M
	2" x 42 x 40	8,45	60 M
	21/4" x 52 x 50	11,68	45 M
	23/4" x 64 x 60	13,20	30 M

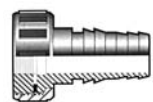
**LIV**

Attacco per serbatoi Tank connector Raccord de reservoir Adaptator para tanque	<b>D</b>	€	<b>Pack.</b>
	3/4" x 16 x 1/2"	9,36	150 S
	1" x 20 x 3/4"	12,40	120 S
	11/4" x 25 x 1"	14,17	
	11/2" x 32 x 1"	17,97	
	2" x 40 x 11/2"	26,55	

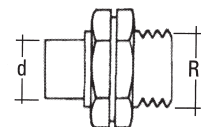

## Serie di passaggio

## Adaptor serie

## Série d'adaptation

## Serie mixta

### T7SK

Ti 90° rinforzato 90° tee with metal ring 90° te avec anneau met. Te a 90° con refuerzo	<b>D</b>	<b>€</b>	<b>Pack.</b>
	16 x 3/8"	2,82	90 XS
	20 x 1/2"	2,82	90 XS
	25 x 3/4"	3,49	100 S+
	32 x 1"	4,36	60 S+
	40 x 1 1/4"	7,69	30 S+
	50 x 1 1/2"	8,95	20 S+
63 x 2"	12,22	10 S+	

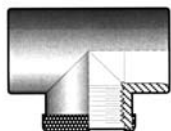

### M7SK

Manicotto rinforzato Socket reinforced Manchon renforcé Manguito con refuerzo	<b>D</b>	<b>€</b>	<b>Pack.</b>
	16 x 3/8"	2,72	300 XS
	20 x 1/2"	2,72	200 XS
	25 x 3/4"	2,72	120 XS
	32 x 1"	3,16	60 XS
	40 x 1 1/4"	3,94	40 XS
	50 x 1 1/2"	5,25	40 S+
63 x 2"	6,33	25 S+	

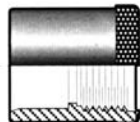

### G7SK

Gomito 90° rinforzato 90° elbow reinforced 90° coude renforcée Codo 90° con refuerzo	<b>D</b>	<b>€</b>	<b>Pack.</b>
	16 x 3/8"	3,83	250 XS
	20 x 1/2"	3,83	130 XS
	25 x 3/4"	3,83	150 S+
	32 x 1"	3,83	40 S+
	40 x 1 1/4"	5,50	20 S+
	50 x 1 1/2"	8,01	30 M
63 x 2"	11,71	45 L	

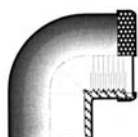

### D7SK

Adattatore rinforzato Adaptor reinforced Embout renforcé Adaptador hembra con refuerzo	<b>D</b>	<b>€</b>	<b>Pack.</b>
	M x F x R		
	20 x 16 x 1/2"	4,39	400 S
	25 x 20 x 1/2"	4,51	350 S
	25 x 20 x 3/4"	5,10	550 M
	32 x 25 x 3/4"	5,31	400 M
	32 x 25 x 1"	5,72	280 M
	40 x 32 x 1"	6,05	250 M
	40 x 32 x 1 1/4"	7,15	180 M
	50 x 40 x 1 1/4"	7,40	140 M
	50 x 40 x 1 1/2"	9,10	110 M
	63 x 50 x 1 1/2"	9,91	90 M
	63 x 50 x 2"	15,71	70 M

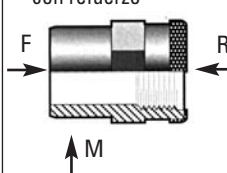

## Bocchettoni metallo PVC/PE

## Union Metal/PVC/PE

## Union Metal/PVC/PE

## Uniones metal PVC/PE

### 5388 SK

Bocchettone F/M ottone / PVC Union F/M brass / PVC Union F/M laiton / PVC Union H/M laiton / PVC	<b>D</b>	<b>€</b>
	16 x 3/8"	19,35
	20 x 1/2"	20,85
	25 x 3/4"	27,77
	32 x 1"	37,22
	40 x 1.11/4"	50,21
	50 x 1.1/2"	63,04
	63 x 2"	90,77
	75 x 2.1/2"	247,75
90 x 3"	302,32	

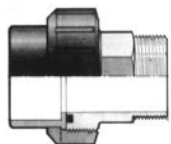

### 5389 SK

Bocchettone F/F ottone / PVC Union F/F brass / PVC Union F/F laiton / PVC Union H/H laiton / PVC	<b>D</b>	<b>€</b>
	16 x 3/8"	13,36
	20 x 1/2"	13,69
	25 x 3/4"	17,31
	32 x 1"	22,71
	40 x 1.11/4"	31,72
	50 x 1.1/2"	43,36
	63 x 2"	64,65
	75 x 2.1/2"	202,08
90 x 3"	232,27	

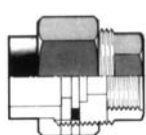

### ADAPEO SK

Adattatore PE/Ottone Adaptor PE/Brass Raccord d'adaptation PE/Laiton Adaptador PE/Laton	<b>D</b>	<b>€</b>
	25 x 3/4"	29,76
	25 x 1"	31,59
	32 x 1"	31,59
	32 x 1 1/4"	38,34
	40 x 1 1/4"	38,34
	40 x 1 1/2"	52,77
	50 x 1 1/2"	52,77
50 x 2"	67,17	
63 x 2"	68,40	



### 5289 SK

Bocchettone F/F ghisa / PVC Union F/F cast iron / PVC Union F/F forte / PVC Enlace H/H hierro / PVC	<b>D</b>	<b>€</b>
	25 x 3/4"	11,59
	32 x 1"	12,89
	40 x 1.11/4"	17,87
	50 x 1.1/2"	22,55
	63 x 2"	35,92
	75 x 2.1/2"	86,57
90 x 3"	128,11	

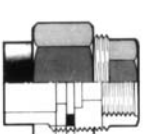

## Raccordi in PVC grandi diametri

Raccordi in PVC grandi diametri

## Big size U-PVC fittings

Big size PVC fittings

## Raccords PVC grand diamètre

Raccords PVC grand diamètre

## Accesorios PVC grandes medidas

Accesorios PVC grandes medidas

### G1SK

	D	€
Gomito 90° Elbow 90° Coude 90° Codo 90°	180 250 280 315	148,40 324,44 479,29 598,74

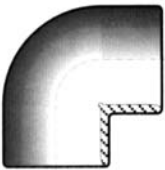

### H1SK

	D	€
Gomito 45° Elbow 45° Coude 45° Codo 45°	200 225 250 280 315	155,08 194,62 275,04 376,05 524,26

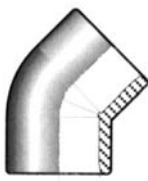

### T1SK

	D	€
Ti a 90° Tee 90° Te à 90° Te a 90°	180 250 280 315	177,54 359,10 564,82 694,60

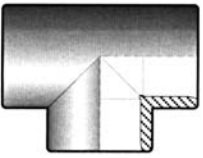

### QR1SK

	D	€
Collare rigato Stub serrated Collet strié pour bride Manguito portabridas estriado	280 315	144,29 165,95



### ODSK

	D	€
Flangia libera Loose flange Bride libre Brida loca	280 315	129,23 142,93



**Raccordi in PVC**  
**grandi diametri**

**Big size PVC fittings**

**Raccords PVC grand diamètre**

**Accesorios PVC**  
**grandes medidas**

**TR1SK**

Ti ridotto 90°  
Reduced Tee 90°  
Te à 90° réduit  
Te a 90° reducida

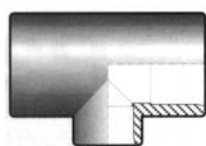

D	€
200 x 90	300,84
200 x 110	300,84
200 x 160	300,84
225 x 90	324,44
225 x 110	324,44
225 x 160	324,44
250 x 110	503,62
250 x 160	503,62
250 x 200	503,62
280 x 160	762,43
280 x 200	762,43
280 x 225	762,43
315 x 160	939,40
315 x 200	939,40
315 x 225	939,40
315 x 250	939,40

**D4SK**

Bussola di riduzione M/F  
Reducing bush M/F  
Douille de reduction M/F  
Casquillo reducio M/H



D	€
225 x 160	65,23
250 x 160	172,79
250 x 200	172,79
250 x 225	172,79
280 x 225	199,93
315 x 200	206,86
315 x 225	206,86
315 x 250	206,86
315 x 280	206,86

**M1SK**

Manicotto  
Socket  
Manchon  
Manguito

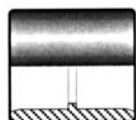

D	€
250	210,96
280	221,95
315	258,81

**FCSK**

Flangia cieca  
Blank flange  
Bride d'opturation  
Brida ciega



D	€
250	278,72
280	284,62

**MR1SK**

Manicotto ridotto  
Reducing socket  
Manchon réduit  
Manguito reducido

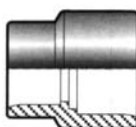

D	€
250 x 110	274,30
250 x 125	274,30
250 x 140	274,30
250 x 160	274,30
250 x 180	274,30
250 x 200	274,30
250 x 225	274,30
280 x 125	320,75
280 x 140	320,75
280 x 160	320,75
280 x 200	320,75
280 x 225	320,75
315 x 160	336,24
315 x 200	336,24
315 x 225	336,24
315 x 250	336,24
400 x 160	401,13
400 x 250	401,13
400 x 280	401,13
400 x 315	401,13
400 x 355	401,13

## Valvole a sfera in PVC

### CARATTERISTICHE

#### Materiali

CORPO: PVC rigido colore grigio  
 GUARNIZIONI:  
 - O-RING in EPDM "Dutral"  
 o FPM "Viton"  
 - Sfera in PTFE "teflon"

#### Temperatura massima di esercizio

60° C

#### Pressione massima di esercizio

16 bar a 20°C dal 16-3/8" al 63-2"  
 10 bar a 20°C dal 75-2/2" al 110-4"

#### Dimensioni e specifiche tecniche

*Incollaggio* in conformità a ISO 727, UNI 7442/75, DIN 8063, NF T54-028, BS4346/1.  
*Fillettatura* in conformità a: UNI ISO 228/1, DIN 2999, BS 21

#### Norme sanitarie

Valvole idonee al convogliamento di acqua potabile, bevande e prodotti alimentari in conformità a leggi e normative dei principali Paesi Europei ed Extra Europei

## uPVC ball valves

### TECHNICAL FEATURES

#### Materials

BODY: Grey unplasticized polyvinyl chloride (U-PVC)  
 GASKETS:  
 - O-RING EPDM or FPM  
 - Ball seat: in PTFE "teflon"

#### Max working temperature

60° C

#### Max working pressure

16 bar at 20°C from 16-3/8" to 63-2"  
 10 bar at 20°C from 75-2/2" to 110-4"

#### Dimensions and specifications

*Solvent welding metric sized ends* according to: ISO 727, UNI 7442/75, DIN 8063, NF T54-028, BS4346/1.  
*Threaded fittings* according to: UNI ISO 228/1, DIN 2999, BS 21

#### Sanitary laws

PVC valves are suitable to be used in contact with drinking water, wine, beverages and food, conforming to laws and rules in force in the main European and Extra European Countries

## Vannes à bille en PVC

### CARACTERISTIQUES

#### Matériel

CORPS: PVC Gris (chlorure de polyvinyle non plastifié)  
 JOINT:  
 - O-RING in EPDM ou FPM  
 - joint à bille PTFE "teflon"

#### Max température d'utilisation

60° C

#### Pression nominale

16 bar à 20°C de 16-3/8" à 63-2"  
 10 bar à 20°C de 75-2/2" à 110-4"

#### Dimensions et caractéristiques

*A coller série métrique* conforme aux normes: ISO 727, UNI 7442/75, DIN 8063, NF T54-028, BS4346/1.  
*Filétage* conforme à: UNI ISO 228/1, DIN 2999, BS 21

#### Normes sanitaires

Vannes aptes au transport de l'eau potable, vin, boissons et fluides alimentaires selon les lois en vigueur dans les principaux pays Européens et Extra Européens

## Valvulas de bola PVC

### CARACTERISTICAS

#### Materialias

CUERPO: cloruro de polivinilo u-PVC gris sin plastificante  
 ASIENTO:  
 - O-RING en EPDM o FPM  
 - asiento de la esfera en PTFE "teflon"

#### Temperatura máxima de trabajo

60° C

#### Presion máxima de trabajo

16 bar a 20°C de 16-3/8" hasta 63-2"  
 10 bar a 20°C de 75-2/2" hasta 110-4"

#### Dimensiones y especificacion tecnicas

*Para union encolada conexiones metricas* conforme a: ISO 727, UNI 7442/75, DIN 8063, NF T54-028, BS4346/1.  
*Uniones roscadas* conforme a: UNI ISO 228/1, DIN 2999, BS 21

#### Normas sanitarias

Valvulas idoneas al transporte de agua potable, vino y fluidos alimenticios segun las leyes y las prescripciones vigentes en Italia y en otros paises Europeos y Extra Europeos

## Serie Industria

### VI1SK

	D	€	Pack.
Valvola industria F/F incollaggio EPDM	16	26,29	50 M
Industry ball valve female ands EPDM	20	27,06	50 M
Robinet à bille "tru block" à coller EPDM	25	33,20	32 M
Valvula de bola para quimica doble union hembra EPDM	32	39,36	22 M
	40	50,62	27 M
	50	64,35	18 M
	63	80,12	10 M
	75	176,91	5 M
	90	227,07	2 M
	110	296,39	1 M



## Industry type

## Serie Industrie

### VI3SK

	D	€	Pack.
Valvola industria F/F incollaggio FPM	16	35,99	50 M
Industry ball valve female ands FPM	20	36,74	50 M
Robinet à bille "tru block" à coller FPM	25	41,79	32 M
Valvula de bola para quimica doble union hembra FPM	32	52,68	22 M
	40	65,56	27 M
	50	82,82	18 M
	63	105,94	10 M
	75	227,18	5 M
	90	288,36	2 M
	110	387,86	1 M



**VB1 SK**

	<b>D</b>	<b>€</b>	<b>Pack.</b>
Valvola bighiera F/F incollaggio			
Double union ball valve female ends for solvent cement	16	15,05	60 S
	20	15,05	60 S
	25	18,24	36 S
Robinet à bille femelle à collar	32	21,76	50 M
	40	28,12	30 M
Valvula de bola double union hembra para encolar	50	30,71	20 M
	63	43,17	12 M
	75	144,39	5 M
	90	187,17	3 M
	110	246,00	2 M

**VB2SK**

	<b>D</b>	<b>€</b>	<b>Pack.</b>
Valvola bighiera F/F filettata			
Double union ball valve female threaded ends	3/8"	16,23	60 S
	1/2"	16,23	60 S
Robinet à bille taraudé femelle	3/4"	19,69	36 S
	1"	23,47	50 M
Valvula de bola double union juntura hembra roscada	1.1/4"	30,39	30 M
	1.1/2"	33,14	20 M
	2"	48,02	12 M
	2.1/2"	155,08	5 M
	3"	208,56	3 M
	4"	267,39	2 M

**VS1 SK**

	<b>D</b>	<b>€</b>	<b>Pack.</b>
Valvola monoghiera F/F incollaggio			
Single union ball valve female ends for solvent cement	16	8,01	60 S
	20	8,01	60 S
	25	9,05	90 M
Robinet à bille femelle simple union à collar	32	10,08	60 M
	40	14,45	35 M
	50	19,59	24 M
Valvula de bola union hembra para encolar	63	33,39	12 M
	75	71,95	5 M
	90	87,18	3 M
	110	159,94	2 M

**VS2SK**

	<b>D</b>	<b>€</b>	<b>Pack.</b>
Valvola monoghiera F/F filettata			
Single union ball valve female threaded ends	3/8"	9,05	60 S
	1/2"	9,05	60 S
Robinet à bille femelle simple union taraudé	3/4"	10,08	90 M
	1"	11,57	60 M
Valvula de bola union hembra roscada	1.1/4"	15,96	35 M
	1.1/2"	20,60	24 M
	2"	34,59	12 M
	2.1/2"	77,96	5 M
	3"	94,45	3 M
	4"	167,20	2 M



**CLAP**

	<b>D</b>	<b>DN</b>	<b>€</b>
Valvola di ritegno a battente in PVC			
	40	32	39,24
PVC Check valve	50	40	36,04
Clapet de retenue en PVC	63	50	43,72
Valvula retencion Clapeta en PVC	75	65	48,10
	90	80	56,86
	110	100	69,58
	140	125	79,63
	160	150	97,60
	225	200	115,10
	280	250	174,88
	315	300	261,83



**VS5SK**

	<b>D</b>	<b>€</b>	<b>Pack.</b>
Valvola monoghiera M/F filettata			
Single union ball valve with female / male threaded end	3/8"	8,01	70 S
Robinet à bille taraudé femelle fileté male	1/2"	8,01	70 S
Valvula de bola union macho / hembra roscada	3/4"	9,60	100 M
	1"	10,81	60 M
	1.1/4"	15,40	40 M
	1.1/2"	19,59	24 M
	2"	33,96	12 M

**VS9SK**

	<b>D</b>	<b>€</b>	<b>Pack.</b>
Valvola nera con attacco femmina filettata / giunto rapido			
Black single union ball valve with female threaded end / quick coupling	16 x 3/8"	10,16	100 M
Robinet noir à bille taraudé F emboitage à compression	20 x 1/2"	10,16	60 M
Valvula de bola negra union hembra roscada / junta rapida	25 x 3/4"	12,24	40 M
	32 x 1"	13,52	24 M
	40 x 1.1/4"	20,86	14 M
	50 x 1.1/2"	23,96	8 M
	63 x 2"	36,19	4 M

**Valvola in Ghisa****Cast-Iron valve****Vanne en fonte****Valvula hiero fundido****10721**

	<b>D</b>	<b>€</b>
Valvola saracinesca ghisa F/F ad anello di gomma rivestimento epossidico		
Cast iron gate valve F/F with rubber ring epoxy coated	50	292,22
Vanne opercule en fonte emboitement joint caoutchouc revetement epoxidique	63	279,08
Valvula de compuerta hierro fundido H/H junta elastica (mecanica) revestimiento epoxidico	75	328,34
	90	380,87
	110	472,80
	125/140	676,37
	160	804,42
	200	1231,26
	250	2203,13
	315	3546,02
	400	7715,87
	500	14770,00

**10725**

	<b>DN</b>	<b>€</b>
Valvola saracinesca ghisa flangiata rivesti- mento epossidico PN 10/16		
Cast iron flanged gate valve epoxy coated PN 10/16	40	279,08
Vanne opercule en fonte a bride revetement epoxidique PN 10/16	50	279,08
Valvula de compuerta hierro fundido PN 10/16 revestimiento epoxidico	60/65	328,34
	80	377,59
	100	472,80
	125	676,37
	150	801,14
	* 200	1231,26
	* 250	2203,13
	* 300	3546,02
	400	7715,87
	500	13790,07



\* Dal diametro d 200 specificare PN -

\* Starting from size d 200 the required PN should be indicated

\* Pression de service doit être spécifié à partir du diamètre d 200

\* Desde el diametro d 200 declarar presion de trabajo requerida

**10703**

	<b>D</b>	<b>€</b>
Prolunga di manovra Extension spindle Rallonge Asta de mando		
	50/63	98,50
	75/90/110	98,50
	125/140/160	98,50
	200	114,92
	250/315	131,33
	400/500	164,17

**10709**

	<b>D</b>	<b>€</b>
Volantino di comando Hand wheel Volant Volante		
	13	22,98
	14	22,98
	17	44,33
	19	57,46
	24	90,29
	27	152,68
	32	229,83



**VR1 OE**

Valvola ritegno molla EPDM F/F  
Check valve with EPDM rubber  
spring female ends  
Clapet de retenue avec ressort  
en EPDM  
Valvula de retention con resor-  
te en EPDM

D	€	Pack.
16	43,96	65
20	43,96	65
25	50,97	65
32	59,58	42
40	66,44	30
50	66,44	18
63	91,79	10
75	195,34	
90	247,02	



**VF1 OE**

Valvola fondo/ Sfogo aria  
incollaggio F/F EPDM  
Foot valve / Air release  
valve female ends EPDM  
Clapet de pied / Ventouse  
F/F EPDM  
Valvula de pie / desaogo  
aire encolaje EPDM

D	€	Pack.
16	36,88	65
20	36,88	65
25	43,96	65
32	51,85	42
40	62,88	30
50	62,88	18
63	81,64	10
75	180,12	
90	224,90	



**14800**

Valvola membrana pneumatica EPDM  
Pneumatic diaphragm valve EPDM  
Vanne à membrane pneumatique EPDM  
Valvula de diafragma pneumatica EPDM

D	€
40	64,02
50	64,02
63	87,92
M x F	
1" 1/4 x 1"	70,86
1" 1/4 x 1" 1/4	70,86



**FARF**

Valvola a farfalla EPDM  
Butterfly valve EPDM  
Vanne à papillon EPDM  
Valvula de mariposa EPDM

D	€
50	201,61
63	137,03
75	139,26
90	164,34
110	187,95
125	211,34
140	214,57
160	237,19
225	338,64
280	793,03
315	3771,71



New!  
New!

**VRUIV**

Valvola di ritegno attacchi a bocchettone  
Check valve with union ends  
Clapet de retenue avec sortie à union  
Valvula de retencion salida enlace

D	€	Pack.
16	77,45	2
20	81,29	2
25	93,73	2
32	109,76	2
40	121,66	2
50	170,94	2
63	267,66	2

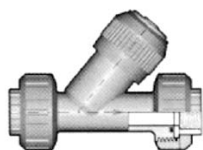

**RVUIV-RVUIT**

**RVUIV:** Raccogli imp.tà attacchi a bocchettone  
Sediment strainer with union ends  
Filtre à tamis avec sortie à union  
**RVUIT:** Raccogli imp.tà trasparente attacchi a  
bocchettone  
Trasparent sediment strainer with union ends  
Filtre à tamis transparent avec sortie à union  
Filtro transparente recogedor de impuridad  
salida enlace

D	€		Pack.
16	70,65	70,65	2
20	72,63	72,63	2
25	82,27	82,27	2
32	107,27	107,27	2
40	133,62	133,62	2
50	176,54	176,54	2
63	222,68	222,68	2



**VRIV**

Valvola di ritegno attacchi femmina  
Check valve with female ends  
Clapet de retenue avec sortie femelle  
Valvula de retencion salida hembra

D	€
75	438,73
90	562,61
110	753,58

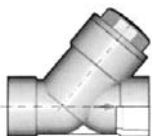

**RVIV-RVIT**

**RVIV:** Raccogli imp.tà attacchi femmina  
Sediment strainer with female ends  
Filtre à tamis avec sortie à femelle  
Filtro recogedor de impuridad salida hembra  
**RVIT:** Raccogli imp.tà trasparente attacchi femmina  
Trasparent sediment strainer with female ends  
Filtre à tamis transparent avec sortie femelle  
Filtro transparente recogedor de impuridad salida hembra

D	€	
75	323,70	323,70
90	368,68	368,68
110	727,04	727,04

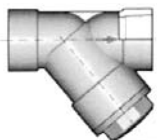

## Raccordi filettati in Polipropilene nero

per irrigazione

## Black Polypropylene fittings

for irrigation

## Raccords filetés Polypropylèn noir

per irrigazione

## Accesorios roscados Polipropileno negro

para riego

### 6061

Niplo Nipple Mamelon Nipple	D	€
	1/2"	0,31
	3/4"	0,36
	1"	0,40
	1 1/4"	0,90
	1 1/2"	1,24
	2"	2,07
	2 1/2"	6,22
	3"	7,40

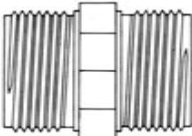

### 6161

Niplo ridotto Reduced nipple Mamelon réduit Nipple reducido	D	€
	3/4" x 1/2"	0,36
	1" x 3/4"	0,50
	1 1/4 x 3/4"	0,90
	1 1/4" x 1"	0,90
	1 1/2 x 1 1/4"	1,38
	2" x 1 1/4"	2,07
	2" x 1 1/2"	2,07
	2 1/2 x 2"	6,55
	3" x 2"	8,63
	3" x 2 1/2"	8,63

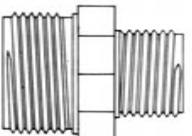

### 6071

Calotta Cap Bouchon femelle Tapon hembra	D	€
	1/2"	0,39
	3/4"	0,42
	1"	0,46
	1.1/4"	0,74
	1.1/2"	1,47
	2"	1,93

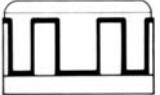

### 6171

Tappo Plug Bouchon mâle Tapon macho	D	€
	1/2"	0,39
	3/4"	0,46
	1"	0,61
	1.1/4"	0,74
	1.1/2"	1,67
	2"	2,28

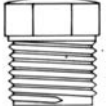

### 6011

Manicotto Socket Manchon Manguito	D	€
	1/2"	1,29
	3/4"	1,46
	1"	1,73
	1.1/4"	3,21
	1.1/2"	3,73
	2"	5,68

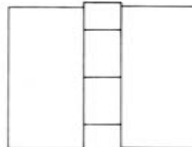

### 6021

Manicotto ridotto Reduced socket Manchon réduit Manguito reducido	D	€
	3/4" x 1/2"	1,42
	1" x 1/2"	2,16
	1" x 3/4"	1,71
	1 1/4 x 1"	2,30
	1 1/2 x 1"	3,45
	1 1/2 x 1 1/4"	3,55
	2" x 1"	5,77
	2" x 1 1/4"	5,77
	2" x 1 1/2"	5,48

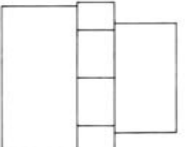

### 6141

T a 90° maschio Male tee 90° Te à 90 mâle T a 90° macho	D	€
	1/2"	0,71
	3/4"	0,95
	1"	1,14
	1 1/4"	1,71

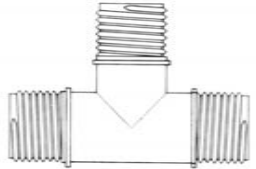

### 6091 / 622

Riduzione M/F lunga Long reduction M/F Reduction longue M/F Reduccion larga M/F	D	€
	3/4" x 1/2"	1,35
	1" x 3/4"	1,54
	1 1/4 x 1/2"	2,52
	1 1/4" x 3/4"	2,28
	1 1/4" x 1"	2,28
	1 1/2 x 1"	3,84
	1 1/2 x 1 1/4"	3,51
	2" x 1"	4,93
	2" x 1 1/4"	4,93
	2" x 1 1/2"	4,93

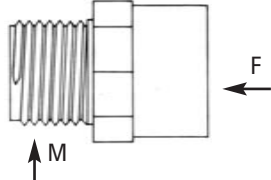

## Raccordi filettati

in Polipropilene nero

per irrigazione

## Black Polupropylene fittings

for irrigation

## Raccords filetés

Polypropylène noir

pour irrigation

## Accesorios roscados

Polipropileno negro

para riego

### 6091 / 623

Bussola di riduzione M/F  
Reducing bush M/F  
Douille de reduction M/F  
Reducion M/H

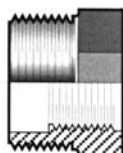

D	€
3/4" x 1/2"	1,04
1" x 1/2"	1,14
1" x 3/4"	1,14
1"1/4 x 1/2"	1,81
1"1/4 x 3/4"	1,81
1"1/4 x 1"	1,81
1"1/2 x 3/4"	3,17
1"1/2 x 1"	3,17
1"1/2 x 1"1/4"	3,17
2" x 1"	4,09
2" x 1"1/4"	4,09
2" x 1"1/2"	4,09
1"1/2 x 2"	7,05
3" x 1"	11,52
3" x 1"1/2"	11,52
3" x 2"	11,52
3" x 2"1/2"	18,06
4" x 2"	18,06
4" x 3"	18,06

### 6051

Gomito 90°  
Elbow 90°  
Coude 90°  
Codo 90°

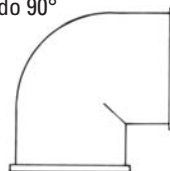

D	€
1/2"	1,66
3/4"	1,91
1"	2,32
1"1/4"	4,33
1"1/2"	7,82
2"	10,70

### 6151

Gomito 90° M/F  
Elbow 90° M/F  
Coude 90° M/F  
Codo 90° M/H

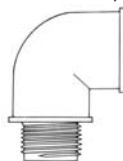

D	€
1/2"	1,66
3/4"	1,91
1"	2,32
1"1/4"	4,30

### 6041

T a 90°  
Tee 90°  
Te à 90°  
T a 90°

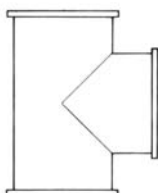

D	€
1/2"	2,42
3/4"	2,57
1"	3,10
1"1/4"	5,68
1"1/2"	9,99
2"	14,37

### 3139

Chiave per idrantino  
Key  
Clé  
Llave para valvula



D	€
3/4"	6,28

### 9181

Gomito filettato maschio  
90° threaded male elbow  
Coude à 90° filetée mâle  
Codo a 90° macho



D	€
1/2"	1,09
3/4"	1,36
1"	1,54
1"1/4"	2,89

### 3039

Idrantino  
Quick valve  
Clapet  
Valvula rapida



D	€
3/4"	15,94
1"	15,94

### 9168

Maggiore PP M/F  
Enlarging piece male-female  
Augmentation filetée mâle-femelle  
Unión macho-hembra



D	€
1/2" x 3/4"	1,98
1/2" x 1"	2,37
1/2" x 1"1/4"	4,42
1/2" x 1"1/2"	5,26
3/4" x 1"	2,37
3/4" x 1"1/2"	5,26
1" x 1"1/4"	4,42
1" x 1"1/2"	5,26
1" x 2"	7,93
1"1/4 x 1"1/2"	5,26
1"1/2 x 2"	7,93

# Raccordi a compressione

## CARATTERISTICHE

### Materiali

CORPO: Polipropilene nero (PP)  
GHIERA: Polipropilene (PP)  
GUARNIZIONI: Gomma nitrilica 75 shore (NBR)  
ANELLO DI SERRAGGIO: Poliacetale bianco  
ANELLI DI RINFORZO: acciaio inox "AISI 430"

### Temperatura massima di esercizio

Polipropilene: 100° C  
Poliacetale: 80° C

### Pressione massima di esercizio

PN16  
PN10 per articoli indicati con "•"  
(massime pressioni di impiego alla temperatura di 20° C)

### Dimensioni e specifiche tecniche

Prodotti conformi alle principali normative Europee quali UNI - ISO - DIN - AFNOR e altre

### Norme sanitarie

Raccordi idonei al convogliamento di acqua potabile, vino, bevande e prodotti alimentari in conformita a leggi vigenti in Italia e nei principali paesi Europei ed Extra Europei

# Compression fittings

## TECHNICAL FEATURES

### Materials

BODY: Black polypropylene  
LOCK nut: polypropylene  
GASKETS: 75 Shore (NBR) nitrilic rubber  
SPLIT: white polyacetale  
REINFORCED RINGS: Stainless steel "AISI 430"

### Max working temperature

Polypropilene: 100° C  
Polyacetale: 80° C

### Max working pressure

PN16  
PN10 for fittings marked with "•"  
(max working pressure at 20° C temperature)

### Dimensions and specifications

According to UNI - ISO - DIN - AFNOR and others

### Sanitary laws

Fittings are suitable to be used in contact with drinking water, wine, beverages and food, conforming to laws and rules in force in Italy and in the main European and Extra European Countries

# Raccords à compression

## CARACTERISTIQUES

### Matériel

CORPS: Polypropylène noir  
BAGUE: polypropylène  
JOINTS: caoutchouc nitrilique  
BAGUE DE BLOPAGE: blanc polyacétale  
BAGUE DE RENFORCEMENT: acier inoxydable AISI 430

### Max température d'utilisation

Polypropylène: 100° C  
Polyacetale: 80° C

### Pression nominale

PN16  
PN10 pour les articles indiqués avec "•"  
(pression maximum de service a la température de 20°)

### Dimensions et caractéristiques

Produits conformes aux normes UNI - ISO - DIN - AFNOR et autres

### Normes sanitaires

Raccords aptes au transport de l'eau potable, vin, boissons et fluides alimentaires selon les lois en vigueur en Italie et dans les principaux pays Européens et Extra Européens

# Juntas rapidas

## CARACTERISTICAS

### Materiales

CUERPO: polipropileno negro P.P.  
TUERCA: polipropileno negro P.P.  
GUARNICIONES: Goma nitrilica 75 shore (NBR)  
CONO DE FIJACION: Poliacetal blanco  
ANILLO DE REFUERZO: Acero inox "AISI 430"

### Temperatura máxima de trabajo

Polipropileno: 100° C  
Poliacetale: 80° C

### Presion máxima de trabajo

PN16  
PN10 por items indicados con "•"  
(maxima presion de trabajo a la temperatura de 20°)

### Dimensiones y especificacion tecnicas

Productos conformes a las normas existentes o en curso de aprovacion UNI - ISO - DIN - AFNOR y otros

### Normas sanitarias

Piezas especiales idoneas al transporte de agua potable, vino y fluidos alimenticios segun las leyes y las prescripciones vigentes en Italia y en otros paises Europeos y Extra Europeos

## Raccordi a compressione

## Compression fittings

## Raccords à compression

## Juntas rapidas

Raccordi a compressione

Compression fittings

Raccords a compression

Juntas rapidas

### 7010-105

	D	€
Manicotto		
Coupling	16	2,08
Manchon	20	2,89
Manguito	25	3,46
	32	4,44
	40	7,18
	50	9,76
	63	13,55
	75	25,49
	90	31,55
	110	67,50



### 7020-95

	D	€
Raccordo maschio		
Male adaptor	16 x 1/2"	1,39
Raccord male	16 x 3/4"	1,39
Racor macho	20 x 1/2"	1,64
	20 x 3/4"	1,64
	25 x 1/2"	1,90
	25 x 3/4"	1,90
	25 x 1"	1,90
	32 x 1/2"	2,43
	32 x 3/4"	2,43
	32 x 1"	2,43
	32 x 1.1/4"	2,66
	32 x 1.1/2"	2,95
	40 x 1"	4,44
	40 x 1.1/4"	4,44
	40 x 1.1/2"	4,44
	40 x 2"	4,63
	50 x 1.1/4"	5,84
	50 x 1.1/2"	5,84
	50 x 2"	5,84
	63 x 1.1/4"	8,33
	63 x 1.1/2"	8,33
	63 x 2"	8,33
	63 x 2.1/2"	8,33
	75 x 2"	16,53
	75 x 2.1/2"	16,53
	75 x 3"	16,53
	90 x 2"	19,53
	90 x 2.1/2"	19,53
	90 x 3"	19,53
	90 x 4"	23,34
	110 x 2"	38,52
	110 x 3"	38,52
	110 x 4"	38,52



### 7110-110

	D	€
Manicotto		
Socket	20 x 16	2,90
Manchon	25 x 16	3,07
Manguito	25 x 20	3,07
	32 x 20	4,14
	32 x 25	4,14
	40 x 25	6,94
	40 x 32	6,94
	50 x 32	9,00
	50 x 40	9,00
	63 x 32	12,78
	63 x 40	12,78
	63 x 50	12,78
	75 x 50	23,25
	75 x 63	23,25
	90 x 63	30,78
	90 x 75	30,78
	110 x 63	64,52
	110 x 75	64,52
	110 x 90	64,52



**7030-100**

Raccordo femmina  
Female adaptor  
Raccord femelle  
Racor hembra



D	€
16 x 1/2"	1,62
16 x 3/4"	1,62
20 x 1/2"	1,97
20 x 3/4"	1,97
25 x 1/2"	2,18
25 x 3/4"	2,18
25 x 1"	2,18
32 x 1/2"	2,66
32 x 3/4"	2,66
32 x 1"	2,66
32 x 1.1/4"	3,69
40 x 1"	4,57
40 x 1.1/4"	4,57
40 x 1.1/2"	4,57
50 x 1.1/4"	6,48
50 x 1.1/2"	6,48
50 x 2"	6,48
63 x 1.1/2"	9,15
63 x 2"	9,15
63 x 2.1/2"	9,15
• 75 x 2"	18,18
• 75 x 2.1/2"	18,18
• 75 x 3"	18,18
• 90 x 2"	22,28
• 90 x 2.1/2"	22,28
• 90 x 3"	22,28
• 90 x 4"	22,28
• 110 x 2"	52,83
• 110 x 3"	52,83
• 110 x 4"	52,83

**7850-130**

Gomito a 90° filett.maschio  
90° elbow with thread male  
Coude à 90° avec dérivation fileté  
Codo 90° rosca macho



D	€
16 x 1/2"	1,84
16 x 3/4"	1,84
20 x 1/2"	1,87
20 x 3/4"	1,87
25 x 1/2"	2,29
25 x 3/4"	2,29
25 x 1"	2,29
32 x 1/2"	2,96
32 x 3/4"	2,96
32 x 1"	2,96
32 x 1.1/4"	3,15
40 x 1"	4,74
40 x 1.1/4"	4,74
40 x 1.1/2"	4,74
50 x 1.1/4"	6,50
50 x 1.1/2"	6,50
50 x 2"	6,50
63 x 1.1/2"	9,03
63 x 2"	9,03
63 x 2.1/2"	9,03
• 75 x 2.1/2"	19,10
• 75 x 3"	19,10
• 90 x 3"	23,97
• 90 x 4"	23,97
• 110 x 4"	46,54

**7040-80**

T a 90°  
90° tee  
Té à 90°  
T de 90°



D	€
16	3,68
20	3,75
25	4,95
32	6,40
40	10,59
50	14,24
• 63	20,29
• 75	35,25
• 90	49,22
• 110	94,91

**7050-120**

Gomito a 90°  
90° elbow  
Coude à 90°  
Codo de 90°



D	€
16	2,25
20	2,89
25	3,51
32	4,38
40	7,55
50	10,59
63	12,83
• 75	24,83
• 90	30,78
• 110	63,73

**7840-90**

T 90° filettato maschio  
 90° tee with threaded male  
 Té à 90° avec dérivation fileté  
 T de 90° rosca macho



D	€
16 x 1/2" x 16	3,01
16 x 3/4" x 16	3,01
20 x 1/2" x 20	3,17
20 x 3/4" x 20	3,17
25 x 1/2" x 25	4,13
25 x 3/4" x 25	4,13
25 x 1" x 25	4,13
32 x 1/2" x 32	5,13
32 x 3/4" x 32	5,13
32 x 1" x 32	5,13
32 x 1.1/4"x32	5,49
40 x 1" x 40	9,03
40 x 1.1/4"x40	9,03
40 x 1.1/2"x40	9,76
50 x 1.1/4"x50	12,80
50 x 1.1/2"x50	12,80
50 x 2" x 50	13,83
63 x 1.1/2"x63	24,79
63 x 2" x 63	24,79
63 x 2.1/2"x63	24,79
• 75 x 2.1/2"x75	37,23
• 75 x 3" x 75	37,23
• 90 x 3" x 90	54,29
• 110 x 4" x 110	89,12

**7150-125**

Gomito a 90° filett.femmina  
 90° elbow with threaded female  
 Coude à 90° avec dérivation taraudée  
 90° codo rosca hembra



D	€
16 x 1/2"	1,87
16 x 3/4"	1,87
20 x 1/2"	2,22
20 x 3/4"	2,22
25 x 1/2"	2,66
25 x 3/4"	2,66
25 x 1"	2,66
32 x 1/2"	3,21
32 x 3/4"	3,21
32 x 1"	3,21
32 x 1.1/4"	4,58
40 x 1"	6,86
40 x 1.1/4"	6,86
40 x 1.1/2"	6,86
50 x 1.1/4"	9,13
50 x 1.1/2"	9,13
50 x 2"	9,13
63 x 1.1/2"	12,39
63 x 2"	12,39
63 x 2.1/2"	12,39
• 75 x 2.1/2"	21,47
• 75 x 3"	21,47
• 90 x 3"	39,70
• 90 x 4"	39,70
• 110 x 4"	61,51

**7340-75**

T a 90° ridotto  
 Tee 90° reduced  
 Té à 90° réduit  
 T de 90° reducida



D	€
20 x 16 x 20	4,74
25 x 20 x 25	4,83
32 x 25 x 32	5,40
40 x 32 x 40	10,59
50 x 40 x 50	14,24
63 x 50 x 63	18,82
• 75 x 63 x 75	35,25
• 90 x 75 x 90	56,03
• 110 x 63 x 110	99,54
• 110 x 90 x 110	99,54

**7320**

Giunto "VICTAULIC"  
 Joint "VICTAULIC"  
 Joint "VICTAULIC"  
 Junta "VICTAULIC"



D	€
• 63 x 2"	8,45
• 110 x 4"	47,00

**7140-85**

T 90° filettato femmina  
 90° tee with threaded female  
 Té à 90° avec dérivation taraudée  
 T de 90° rosca hembra



	<b>D</b>	€
	16 x 1/2" x 16	2,93
	16 x 3/4" x 16	2,93
	20 x 1/2" x 20	3,24
	20 x 3/4" x 20	3,24
	25 x 1/2" x 25	4,21
	25 x 3/4" x 25	4,21
	25 x 1" x 25	4,61
	32 x 1/2" x 32	5,22
	32 x 3/4" x 32	5,22
	32 x 1" x 32	5,22
	32 x 1.1/4" x 32	6,54
	40 x 1" x 40	9,95
	40 x 1.1/4" x 40	9,95
	40 x 1.1/2" x 40	10,72
	50 x 1.1/4" x 50	13,29
	50 x 1.1/2" x 50	13,29
	50 x 2" x 50	14,87
	63 x 1.1/2" x 63	18,98
	63 x 2" x 63	18,98
•	63 x 2.1/2" x 63	24,30
•	75 x 2" x 75	32,88
•	75 x 2.1/2" x 75	32,88
•	75 x 3" x 75	32,88
•	90 x 3" x 90	50,99
•	110 x 3" x 110	76,89
•	110 x 4" x 110	76,89

**7120-115**

Tappo fine linea  
 End cap  
 Bouchon de fermeture  
 Tapon terminale



	<b>D</b>	€
	16	1,51
	20	2,06
	25	2,22
	32	2,66
	40	4,44
	50	6,55
	63	8,86
	75	21,01
	90	24,05
	110	51,79

**7220-135**

Raccordo flangiato  
 Flanged joint  
 Joint à bride  
 Enlace con brida

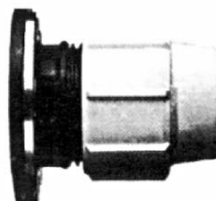

	<b>D</b>	€
	50 x 1.1/2"	43,99
	50 x 2"	43,99
	63 x 2"	48,61
	75 x 2.1/2"	62,51
	90 x 3"	86,81
	90 x 4"	101,87
	110 x 4"	113,44

## Prese a staffe

## Clamp saddles

## Colliers de prise

## Collarin de toma

### 6076

Prese a staffa con anello di rinforzo  
Clamp saddles with reinforcing ring  
Colliers de prise avec anneau de renforce  
Collarin de toma con anillo de refuerzo



		D								€
20 x	1/2									3,39
25 x	1/2	3/4								3,46
32 x	1/2	3/4								3,81
32 x			1"							4,03
40 x	1/2	3/4	1"							4,15
50 x	1/2	3/4	1"	1 1/4"						4,45
63 x	1/2	3/4	1"	1 1/4"	1 1/2"					5,76
75 x	1/2	3/4	1"	1 1/4"	1 1/2"	2"				7,30
90 x	1/2	3/4	1"	1 1/4"	1 1/2"	2"				8,31
110 x	1/2	3/4	1"	1 1/4"	1 1/2"	2"				9,85
110 x								3"		14,40
125 x		3/4	1"	1 1/4"	1 1/2"	2"				12,56
140 x			1"	1 1/4"	1 1/2"	2"				18,61
140 x							2 1/2"	3"		30,62
160 x		3/4	1"	1 1/4"	1 1/2"	2"				26,46
160 x								3"		37,76
180 x			1"	1 1/4"	1 1/2"	2"		3"	4"	122,36
200 x				1 1/4"	1 1/2"	2"				106,36
200 x								3"	4"	109,30
225 x				1 1/4"	1 1/2"	2"		3"	4"	132,07
250 x				1 1/4"	1 1/2"	2"		3"	4"	153,68
280 x				1 1/4"	1 1/2"	2"		3"	4"	207,35
315 x				1 1/4"	1 1/2"	2"		3"	4"	195,75

### 6086

Prese a staffa  
Clamp saddles  
Colliers de prise  
Collarin de toma



		D								€
20 x	1/2									1,64
25 x	1/2	3/4								1,64
32 x	1/2	3/4								1,64
32 x			1"							1,91
40 x	1/2	3/4	1"							2,05
50 x	1/2	3/4	1"	1 1/4"						2,39
63 x	1/2	3/4	1"	1 1/4"	1 1/2"					3,46
75 x	1/2	3/4	1"	1 1/4"	1 1/2"	2"				5,45
90 x	1/2	3/4	1"	1 1/4"	1 1/2"	2"				6,44
110 x	1/2	3/4	1"	1 1/4"	1 1/2"					6,84
110 x						2"		3"		10,43

## Accessori

## Accessories

## Accessoires

## Accessories

### 6085

Fermatubo PE-Nero Support Clip PE-Black Clip de fixation PE-Noir Sujeta Tubo PE-Negro	<b>D</b>	€
	○ 16	0,56
	○ 20	0,63
	○ 25	0,81
	○ 32	0,92
	□ 40	1,84
	□ 50	2,36
	□ 63	2,79
	□ 75	3,60
	□ 90	4,79
	□ 110	5,58



### TANGIT

Collante Glue Colle Cola	<b>Gr.</b>	€
	1000	72,35

### DEKAP

Detergente Cleaner Décapant Detergente	<b>Lt.</b>	€
	0,5 1	13,65 21,00

### GLUE

Collante per PVC Glue for PVC Colle pour PVC rigide Cola para PVC	<b>Gr.</b>	€
	500 1.000	28,88 47,25

### TEFLON

Nastro Teflon Teflon ribbon Ruban Teflon Nastro Teflon	<b>d</b>	€
	mt. 12 x 1/2"	1,05

### SCIVO

Scivolante Lubricant Pâte lubrifiante Lubricante	<b>ml.</b>	€
	500 1.000	7,35 10,50

#### Dimensione cartoni

XS = 30x20x20  
 S = 40x30x20  
 M = 40x30x30  
 L = 60x40x30  
 L+ = 60x40x50  
 XL = 80x120x80

#### Cartons dimension

XS = 30x20x20  
 S = 40x30x20  
 M = 40x30x30  
 L = 60x40x30  
 L+ = 60x40x50  
 XL = 80x120x80

#### Dimension cartons

XS = 30x20x20  
 S = 40x30x20  
 M = 40x30x30  
 L = 60x40x30  
 L+ = 60x40x50  
 XL = 80x120x80

#### Dimension cartones

XS = 30x20x20  
 S = 40x30x20  
 M = 40x30x30  
 L = 60x40x30  
 L+ = 60x40x50  
 XL = 80x120x80

LISTINO PREZZI N° 3  
PRICE LIST N° 3

GENNAIO 2008  
JANUARY 2008

	SCONTO/DISCOUNT
<b>RACCORDI IN PVC CON ANELLO DI GOMMA</b> <i>UPVC RUBBER RING FITTINGS</i> (pag. 1 - 3)	
<b>RACCORDI IN PVC CON ANELLO DI GOMMA</b> <i>UPVC RUBBER RING FITTINGS</i> (pag. 4 - 5)	
<b>RACCORDI IN PVC RIGIDO</b> <i>UPVC PRESSURE FITTINGS</i> (pag. 6 - 17)	
<b>RACCORDI IN PVC GRANDI DIAMETRI</b> <i>BIG SIZE U-PVC FITTINGS</i> (pag. 18 - 19)	
<b>VALVOLE A SFERA IN PVC</b> <i>UPVC BALL VALVES</i> (pag. 20 - 23)	
<b>RACCORDI FILETTANTI IN POLIPROPILENE NERO</b> <i>BLACK POLYPROPYLENE FITTINGS</i> (pag. 24 - 25)	
<b>RACCORDI A COMPRESSIONE</b> <i>COMPRESSION FITTINGS</i> (pag. 26 - 31)	
<b>ACCESSORI</b> <i>ACCESSORIES</i> (pag. 32)	

### Condizioni generali di Vendita

Le presenti condizioni generali sono applicabili a tutte le ordinazioni pervenuteci dopo l'emissione del presente listino; sono soggette a cambiamento senza alcun preavviso e si intendono accettate integralmente con il conferimento dell'ordinazione.

1 ) Prezzi: saranno applicati quelli in vigore alla data di consegna  
2) Termini di consegna: Pronta, salvo venduto. È facoltà del venditore evadere l'ordine in più riprese senza che ciò dia diritto all'annullamento dell'ordine o di parte di esso.

La merce è venduta franco i nostri magazzini di Fiesso Umbertino.

3) Spedizione: nei casi in cui il mezzo di spedizione non sia esplicitamente indicato dal cliente, la spedizione verrà effettuata nel modo da noi ritenuto più idoneo. La merce viaggia a rischio e pericolo del Committente, anche se spedita in porto franco. L'assicurazione viene coperta solo su richiesta ed è a carico del compratore.

4) Reclami: eventuali reclami devono essere fatti entro 30 giorni dalla data di fatturazione a mezzo lettera raccomandata e nei termini prescritti dal Codice Civile. Non vengono accettati materiali di ritorno se non preventivamente autorizzati da ns. funzionari competenti .

5) Imballo: normale, gratis. Imballi particolari, se richiesti verranno addebitati al costo.

6) Garanzia: il nostro materiale si intende garantito per i guasti dovuti a difetto di costruzione, di materiale o di lavorazione a noi imputabili.

La garanzia decade qualora:

- Sia trascorso fino a un anno dalla consegna del materiale .
- Il materiale sia impiegato al di fuori delle condizioni di esercizio da noi indicate.
- Il materiale sia stato comunque modificato o manipolato.

La nostra garanzia si limita alla sostituzione dei prodotti difettosi o alla loro riparazione nella nostra Sede con la completa esclusione di qualsiasi altra responsabilità ed particolare con l'esclusione di indennizzi o riconoscimento di danni comunque causati dall'uso dei nostri prodotti.

7) Pagamento:

-contro tratta o ricevuta bancaria a vista:  
sconto 3%

-contro tratta a 30 gg. data fattura: prezzo netto

-Altre forme di pagamento: da concordare.

I pagamenti effettuati a mezzo rimessa diretta devono esser fatti alla ns. Sede di Fiesso Umbertino. Per il ritardato pagamento si applicheranno interessi moratori ai tassi bancari correnti al momento dell'inadempienza. Per le forniture all'estero il pagamento deve essere effettuato mediante apertura di credito irrevocabile. Per ogni controversia è competente il Foro di Rovigo.

8) Riserva di proprietà: i prodotti forniti resteranno di nostra proprietà fino al totale pagamento di essi.

### General Sales Conditions

*The general terms herewith apply to all orders which have reached us after the sending of the included list herein, they are subject to variation without any notice, and they are believed to be integrally accepted with the bestowal of the order.*

*1 ) Prices: At delivery's date, prices which are in force will be applied.*

*2) Delivery time: Early delivery is subject prior sale. The seller has the power of dispatching in several occasions the order, without giving thus the right to the cancelling of the commission or of a part of it. The goods are sold factory free at our warehouse of Fiesso Umbertino.*

*3) Forwarding: When the means of conveyance are not explicitly shown by the customer, the delivery shall take place through ways wick we consider the most suitable. The goods travel at risk and danger of the purchaser, even if they are sent duty free. The Insurance is covered only by request and is to be charged to the buyer*

*4) Complaints: Eventual complaints should be made within 30 days from the date of delivery sent by a full postage letter and in terms regarding the civil law. Returning material will not be accepted if not firstly authorised by competents officials.*

*5) Packing: standard, free.*

*If required, special packages will be charged with the cost.*

*6) Guarantee: our material is understood to be guaranteed against damages due to construction fault, that is fault of material and machining defects which are imputable to us.*

*The guarantee expires:*

*-One year after the goods delivery.*

*-If the material is to be employed out of the operating terms which we have indicated.*

*-If the material is altered or manipulated.*

*Our guarantee limits itself to the replacement of the faulty products or to their repairing in our head office, excluding completely any other responsibility and particularly excluding indemnities or to the acknowledgement of damages caused by our products.*

*7) Payment:*

*-Against draft or bank receipt at sight: 3 per cent discount*

*-Against draft at 30 days from the date of the bill: net price*

*-Against other form of payment: to be agreed upon. Effectual payments done directly must be undertaken at our own residence in Fiesso Umbertino. In case late payments we will apply penalties according to the current bank taxes from the unaccomplished date. For overseas supplies payments should be effected by opening a credit account which will inexorable.*

*For any controversy it is convenient to report to the law Courts of Rovigo.*

*8) Reserved ownership: Products which are delivered will retain our own property until the the payment will be effected. These general conditions cancel the previous ones and are subject forward notice.*